



Australian
Institute of
Architects

Condensation in Buildings



2011

Handbook

NON-MANDATORY DOCUMENT



CONDENSATION IN BUILDINGS

INFORMATION HANDBOOK

2011





Important Notice and Disclaimer

The Australian Building Codes Board (ABCB) and the participating Governments are committed to enhancing the availability and dissemination of information relating to the built environment. Where appropriate, the ABCB seeks to develop non-regulatory solutions to building and related issues.

This Handbook on Condensation in Buildings (the Handbook) is provided for general information only and should not be taken as providing specific advice on any issue. In particular, this Handbook is not mandatory or regulatory in nature. Rather, it is designed to assist in making information on this topic readily available.

The ABCB, the participating Governments, and the groups which have endorsed or been involved in the development of the Handbook, do not accept any responsibility for the use of the information contained in the Handbook and make no guarantee or representation whatsoever that the information is an exhaustive treatment of the subject matters contained therein or is complete, accurate, up-to-date or reliable for any particular purpose.

The ABCB, the participating Governments and groups which have endorsed or been involved in the development of the Handbook expressly disclaim all liability for any loss, damage, injury or other consequence, howsoever caused (including without limitation by way of negligence) which may arise directly or indirectly from use of, or reliance on, this Handbook.

The material in this Handbook does not constitute the provision of professional advice. Users should exercise their own skill and care with respect to their use of this Handbook and should obtain appropriate independent professional advice on any specific issues concerning them prior to relying on, or entering into any commitment based on material in this Handbook. In particular, and to avoid doubt, the use of this Handbook does not –

- guarantee acceptance or accreditation of a design, material or building solution by any entity authorised to do so under any law;
- mean that a design, material or building solution complies with the National Construction Code (NCC); or
- absolve the user from complying with any Local, State, and Territory or Australian Government legal requirements.



© Australian Government and States and Territories of Australia 2011

This work is copyright. Apart from any use as permitted under the Copyright Act 1968, no part may be reproduced by any process without prior written permission from the Commonwealth and State and Territory Governments of Australia. Requests and inquiries concerning reproduction and rights should be addressed to the:

General Manager – Australian Building Codes Board
GPO Box 9839
Canberra ACT 2601

Phone 1300 134 631 – Fax 02 6213 7287



Preface

This Handbook is issued by the ABCB. The information contained in the Handbook has been developed in order to provide additional information, detail and advice relating to the management of the risk of condensation in buildings, particularly the interstitial spaces within the roof and walls of framed buildings. The presence of condensation, particularly within the concealed voids of buildings gives rise to infestations of fungus and mould which have the potential to be injurious to the health of occupiers, and, which can accelerate the deterioration of building materials including structural components. The development of condensation and its effects may compromise achievement of the general objectives relating to safety and health, and amenity and sustainability of the National Construction Code (NCC) Volumes One and Two – the Building Code of Australia.

The Handbook was commissioned because of an increase in the incidence of condensation causing damage and loss which has occurred as a result of changes to building materials and practices that have and continue to transform the industry. This handbook does not deal with internal condensation or mechanical condensation formation within buildings.

This document aims to assist practitioner understanding of what to take into consideration to minimise the risk of condensation in both new and existing buildings and to assist in compliance with the Building Code of Australia.



Acknowledgements

This Handbook was developed by industry, coordinated by the Australian Institute of Architects and is issued by the ABCB to assist in disseminating information to building and construction practitioners. This Handbook could not have been developed without the assistance and technical expertise of the following people:

Jamie Adams,	BlueScope Steel
Richard Aynsley,	Building Scientist
Robin Fardoulys,	Fardoulys Constructions, Chairman Australian Construction Industry Forum
James M Fricker,	Consulting Engineer
Mark Goodchild,	Master Builders Association, NSW
Carmel McCormack,	Australian Institute of Architects
Andy Russell,	Proctor Group Australia
Peter Sarlos,	Peter Sarlos Architect
David Shultis,	Cox Architecture
Mark Sonnemann,	Cundall Engineers
Phil Wilkinson,	Australian Institute of Refrigeration Air Conditioning and Heating



Table of Contents

Important Notice and Disclaimer	iii
Preface	v
Acknowledgements.....	vi
Table of Contents	vii
Definition of Terms.....	viii
Chapter 1 Overview	1
Chapter 2 Condensation Principles	3
Chapter 3 Consequences of Condensation	11
Chapter 4 Risk Assessment	17
Chapter 5 Designing to Avoid Condensation	27
Chapter 6 Existing Regulations and Standards.....	51
Appendix A Case Studies	57
Appendix B Examples of Risk Analysis	79
Appendix C Supplementary Material	87

Definition of Terms

Air-Conditioning

The mechanical conditioning of internal air temperature to within a prescribed range.

Building Fabric

The materials and systems used for the construction of a building which includes, but is not limited to, insulation, cladding and roofing materials.

Capillary Suction

The process by which a liquid will enter a porous medium as a result of capillary forces.

Condensation

The process used to describe moisture formation on a surface as a result of moist air coming into contact with a surface which is at a lower temperature. As cool air is unable to retain the same amount of water vapour as warm air, excess moisture is released as condensation.

Dew Point

The temperature at which the relative humidity of the air reaches 100%, at which time saturation occurs and water vapour contained in the air will begin to condense. The dew point temperature of the air depends upon the air temperature and the humidity of the air and can be determined using a psychrometric chart.

Dry Bulb Temperature

A measure of the temperature of the air, excluding the influence of radiation and moisture.

Together with the wet bulb temperature, relative humidity and dew point at the ambient temperature can be determined.

External Moisture

The penetration of moisture into the building cavity through various sources such as rain, capillary action, leaks, solar driven moisture, air movement and vapour diffusion.

External Side

The weather side of a building material or membrane, i.e. the surface of a material or membrane closest to the exterior of the building

HVAC

Acronym for Heating, Ventilation and Air-Conditioning.

Hygroscopic Materials

Materials which have the ability to absorb moisture from the air.

Internal Moisture

Moisture generated by both human activities inside a building by activities such as breathing, sweating, cooking, clothes drying or showering, etc.

Internal Side

The room side of a building material or membrane, i.e. the surface of a material or membrane closest to the interior of the building.

Interstitial Condensation

Interstitial condensation occurs as a result of moisture diffusing through the permeable building fabric from the high vapour pressure side to the low vapour pressure side. As the air is moving through the building fabric, it can be cooled, in the process increasing the moisture saturation of the air. Where the temperature drops sufficiently to cause the air to reach saturation, water vapour in the air can condense out. The point at which this occurs is called the dew point which is the point where condensation occurs.

Microclimate

The unique local climate which is measurably different to the general climate of the region.

Moisture Sorption Isotherm

The relationship between water activity and moisture content at a given temperature. This relationship is complex and unique for each material due to different interactions (colligative, capillary, and surface effects) between the water and the solid components at different moisture contents.

Off-gassing

The sweating of volatile gases and water vapour from building materials.

Pliable Building Membrane (or underlay)

A pliable material, which may be installed to act as a sarking membrane, thermal insulation or vapour barrier.

Psychrometric Chart

A chart of the physical properties of moist air for a particular altitude or air pressure. It can be used to determine the dew point temperature and moisture content of air for a defined set of conditions.

Purlins

The horizontal structural component of a roof running between the trusses and providing a mechanism for roof cladding attachment commonly in relation to roof decking.

Relative Humidity (RH)

Measure of the amount of water vapour in the air relative to the maximum amount of water that the air can hold at a given temperature.

Sarking

A material located behind the external linings used primarily to prevent penetration of water into a building.

Sick Building Syndrome

A term used to describe a range of symptoms, such as breathing difficulties, itchy eyes, skin rashes, and nasal allergy, which may be triggered when the sufferer spends time in a particular building.

Smart Vapour Retarder (Variable Permeability Vapour Retarder)

A membrane that changes from restricting to allowing the transmission of water vapour depending upon the temperature or relative humidity where it is located.

Sol-air temperature

The notional outdoor temperature that in the absence of radiation would have the same heat flow through a building element as the actual combination of outdoor temperature and radiation.

Surface Condensation

Surface condensation takes place on the surface of a body when the temperature of the surface is less than the dew point temperature of the surrounding warm moist air.

Thermal Conductivity

A measure of the ability of a material to conduct heat.

Thermal Mass

The ability of a material to absorb and store heat. Higher thermal mass can assist in regulating the air temperature inside a building.

Thermal Bridging

Term given to heat transfer through a conductive or convective path that generally bridges past a high insulating material or construction.

Thermal Resistance

A measure of the ability of a material to resist heat transfer.

Vapour Barrier

Vapour impermeable layer used to prevent the penetration of water vapour either into a building or from inside into the cavity of the building fabric: For Vapour Barrier Classification see AS4200 (1994) Part 1.

Vapour Diffusion

The result of vapour pressure difference between indoor and outdoor air conditions. The rate of diffusion depends upon the permeability of the linings and materials that make up the building fabric.

Vapour Permeable (Breathable) Membrane

A membrane intended to allow the transmission of water vapour. This is often also referred to as a breathable membrane or breathable underlay.

Vapour Pressure

A physical property of a substance, related to the temperature of the air and the amount of moisture contained in the air and barometric pressure that describes how readily it evaporates. For the same relative humidity, the higher the temperature, the higher the vapour pressure. For the same temperature, the higher the relative humidity, the higher the vapour pressure.

Vapour resistance

A measure of a material's reluctance to let water vapour pass through.

Vapour resistivity

The resistance per unit thickness to water vapour of a homogeneous body.



Ventilation air latent energy load

The energy related to the moisture content in the air supplied for ventilation.

Water Vapour Transmission Rate (WVTR)

Also referred to as the moisture vapour transmission rate (MVTR), this is the measure of the diffusion water vapour through a substance.

Wet Bulb Temperature

Wet-bulb temperature reflects the physical properties of a system with a mixture of a gas and a vapour, usually air and water vapour. Wet bulb temperature is the lowest temperature that can be reached by the evaporation of water only. It is the temperature felt when the skin is wet and is exposed to moving air.

Chapter 1 Overview

This Handbook is intended to assist architects, designers and builders in the assessment and the management of the risk of condensation and its consequences in the contemporary industry environment and should be read in conjunction with the BCA provisions relating to Damp and Weather Proofing, Energy Efficiency and Construction in Bushfire Prone Areas.

Appropriate detailing of buildings ensures they remain serviceable, the occupants remain healthy and that the design life of the building is not compromised. The outcome of failing to adequately detail for moisture control is a common underlying cause of many reported building failures. Experience in Australia and overseas has shown that the incorrect use of sarking, the manner of and extent of insulation installations and lack of adequate ventilation have resulted in condensation which has in turn resulted in the decay of timber products, the failure of internal linings and corrosion of steel. In the United States, Canada and Europe the selection and installation of inappropriate pliable membranes have resulted in the extensive decay of timber framing and linings¹. In New Zealand inappropriate wall detailing has resulted in a significant number of newly constructed homes experiencing severe decay of wall framing and damage to buildings' fabric² resulting in significant multi-party litigation to establish liability. The rectification of the side-effects of condensation can result in costly repairs and in the case of related fungal and mould infestations, prohibitively expensive repairs.

The problem of moisture in buildings is often perceived to be negligible in Australia due to our warmer climate, construction methods and history of damage. That perception is wrong and places the parties responsible for the design and delivery of a building at risk of liability and the owner and occupiers at risk of financial loss and compromised health.

Traditionally our buildings were not airtight and had little or no insulation. However, as a result of changing occupant practices (such as closing windows to exclude external noise or retain conditioned air) and the introduction of mandatory energy efficiency and enhanced bushfire construction requirements, building practices are changing, requiring a change in detailing so that moisture related problems are adequately managed.

¹ Tsongas G & Olson J D, *Tri State Homes: A case study of extensive decay in the walls of older manufactured homes with an exterior vapour retarder. Thermal Performance of Exterior Envelopes of Buildings VI Conference Proceedings, Florida, December 1995*

² D Hunn et al., *Report of the overview group on the weathertightness of buildings to the Building Industry Authority, New Zealand, 31 August 2002*

- New buildings are significantly more airtight than those constructed in the past. As a result the moisture development and the impact of moisture will be more pronounced. The reduced ventilation of a building, including interstitial areas, facilitates the accumulation of moisture, the lack of ventilation severely restricting drying out. This in turn facilitates the development of mould, fungus and corrosion, usually undetected until the problem externalises as fungus and mould on the surfaces of a room.
- The processes that are occurring in colder climates and temperate climates with colder winters are brought about by a lowering of the temperature within wall and roof spaces which in turn increase the risk of condensation. Insulation levels have increased considerably. In cold climates greater amounts of insulation results in cooler external surfaces and in hot climates cooler internal surfaces.
- In warmer climates and in some air-conditioned environments there is a risk that the internal areas are cooler and that the condensation will occur on the internal surfaces of functional areas or against the material bounding permeable internal surfaces.

It is important that buildings are appropriately detailed to ensure that Australian buildings do not suffer similar problems to those that have been experienced in other parts of the world.

While a common cause of moisture related problems is due to water ingress, the focus of this handbook is controlling moisture within the building's fabric resulting from condensation.

Chapter 2 Condensation Principles

This chapter defines and explains how condensation can occur in buildings and discusses strategies for managing condensation by understanding the movement of air and moisture (water or water vapour) in the building fabric and the storage of moisture in the building fabric. Local climate considerations are discussed in the context of identifying the appropriate climate for assessing condensation risk.

2.1 What is condensation?

Air contains invisible water vapour. The higher the air temperature, the more water vapour it can hold. The lower the air temperature, the less water vapour it can hold. Where warm air contacts a cold surface, it cools. When the air cools below a temperature known as the '**dew point**', invisible water vapour condenses to visible water droplets on the cold surface. The water that is formed is known as condensate and the process is called condensation. If more water vapour is present, further condensation occurs which may lead to a trickle of condensate. However, the process is reversible - if the surface is warmed above the dew point, the condensation will evaporate and may leave the surface dry.

Common examples of surface condensation include:

- condensation upon a glass of cold beer as a result of the reduced temperature of the glass in the warm environment
- condensation upon a bathroom mirror as a result of increasing the moisture levels within the room.

2.2 Condensation in buildings

Condensation within a building can form as visible **surface condensation** or can form on surfaces within the building fabric, known as **interstitial condensation**. In cold weather, interstitial condensation is caused when water vapour inside a building is able to move outward via diffusion through permeable building fabrics or air movement and reach a surface within the building cavity that is below the dew point. That surface may be smooth such as sheet metal, or fibrous, such as glasswool insulation. A cold surface that condenses vapour absorbs the heat of vapourisation, raising its temperature slightly. Thus condensation can be most rapid on a metal frame, and less rapid on an insulation material. But given time, both might condense a considerable amount of water.

Interstitial condensation can be far more damaging to the building than surface condensation. Interstitial condensation can go unnoticed and if the building fabric has not been designed to allow moisture to dry from within it can become trapped and compromise the durability of the building and the health of the occupants.

The factors that contribute to condensation in buildings are essentially one or more of the following:

- the presence of moisture levels which are too high;
- the presence of temperatures in the building fabric which are too low; and
- uncontrolled flow of water vapour from a source to a region of cold temperature.

Moisture levels within buildings are often higher than outdoors. The main cause of high indoor moisture levels is the generation of warm moist air by domestic activities. Heaviest loads are produced by:

- cooking
- bathing/ showering
- clothes drying
- high occupancy
- high indoor plant concentrations
- uncontrolled moisture ingress.

All of these factors contribute to raising the indoor relative humidity (RH). An increase in RH increases the dew point temperature for the same air temperature. This increases the risk of condensation should the water vapour come into contact with a surface below dew point.

2.3 The psychrometric chart

Condensation will form on a surface when its temperature drops to the dew point temperature of the surrounding air. The dew point temperature of the air depends upon the air temperature and the humidity of the air. This relationship is illustrated using a psychrometric chart, see Figure 2.1.

Figure 2.1 The psychrometric chart

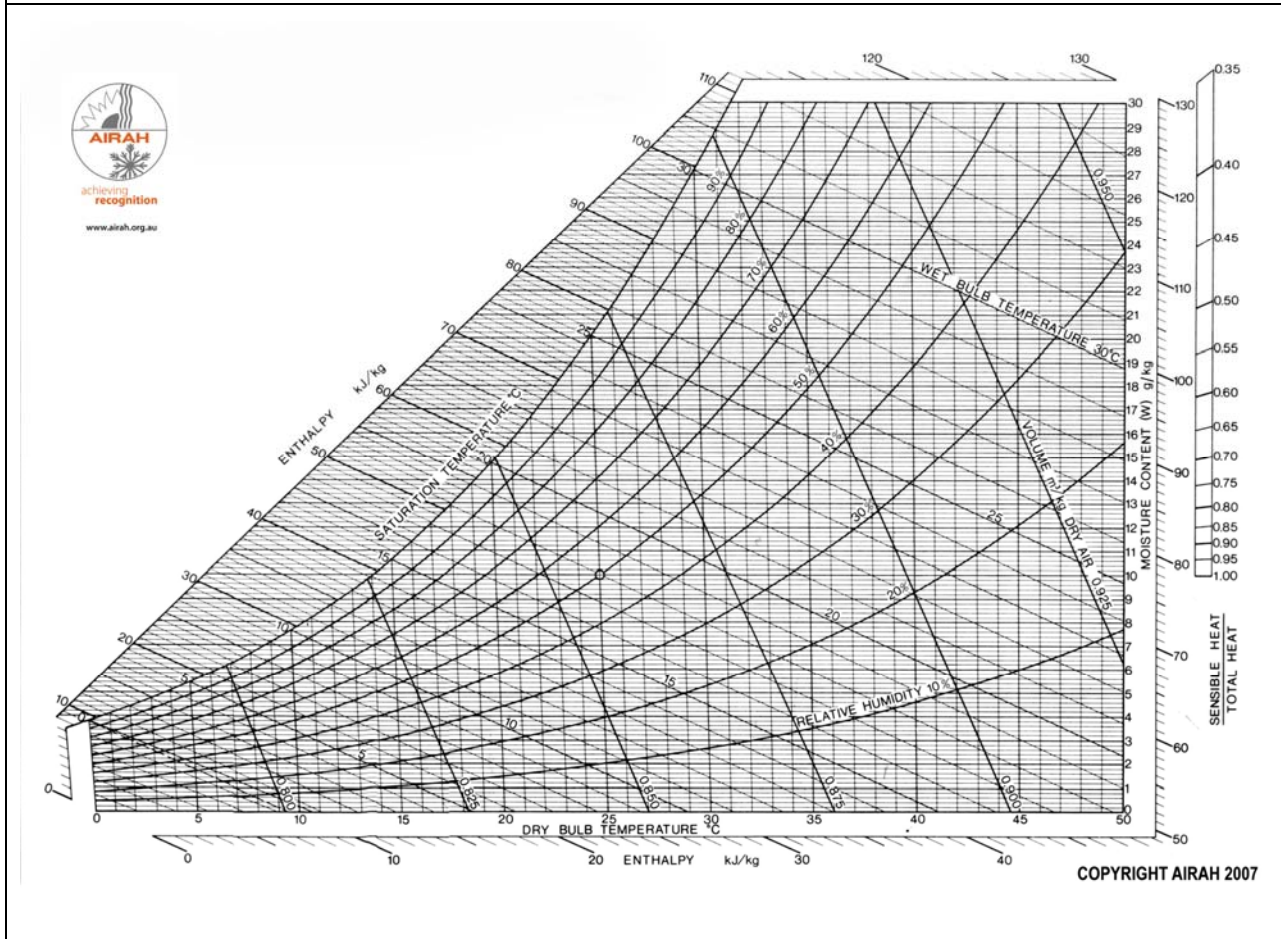

Figure 2.1 is read as follows:

- dry bulb temperature (air temperature) - vertical lines (values along the bottom)
- relative humidity – curved lines (values along the top and right hand side)
- dew point temperature – represented by the 100% relative humidity line (values along the 100% humidity line)
- wet bulb temperature – lines sloping upward to the left (values along the 100% humidity line)
- moisture content – horizontal lines (values not shown when it is expressed as a fraction)

The chart shows that the higher the air temperature, the more moisture that can be held in the air. An example of how to use the chart to determine dew point temperature is shown. For 30 °C air temperature and 50 % relative humidity, the dew point temperature is 18.3 °C. For 30°C air temperature and 71% relative humidity, the dew point temperature is 24.2°C, which is within the range of indoor air temperatures in air-conditioned space in Darwin.

Dew point values have been used to generate Figure 2.2, which provides an approximate relationship between the surface temperature drop from the air temperature to the relative humidity of the air. If the relative humidity and air temperature is known, then the dew point temperature of the surface is easily estimated. For example, at 50% relative humidity the surface can be about 10.5 °C below the air temperature without condensation forming. At 90% relative humidity the surface need only be about 1.5 °C below the air temperature if condensation is to be avoided.

Figure 2.2

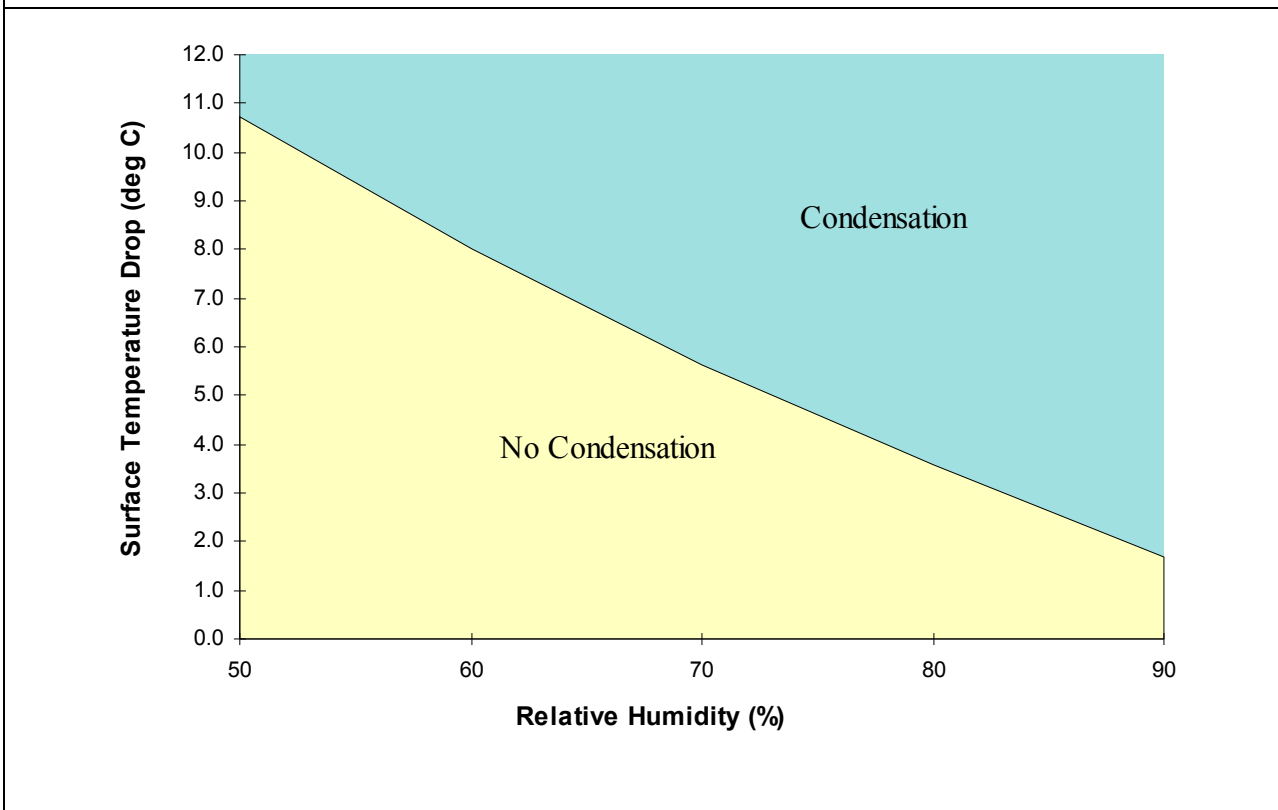

Note: Precise numerical values for dew point temperatures along the condensation line in Figure 2.2 are provided in Appendix B of this Handbook.

2.4 The influence of building materials

Controlling condensation upon and within the building fabric requires an understanding of the movement and storage of moisture. Transport of moisture into the building fabric can be via diffusion of water through linings or via air movement.

- Vapour diffusion through linings occurs as a result of vapour pressure difference between indoor and outdoor linings. The rate of diffusion depends upon the vapour permeability of the linings that make up the building fabric and is referred to as the water vapor transmission rate (WVTR).
- Air movement through the fabric occurs as a result of gaps within the building fabric that are not fully sealed.

The latter is far more critical and is why it is important that the internal wall lining (plasterboard) be installed at the edges to be as airtight as physically possible (providing a quality air barrier) to limit unintended infiltration of warm moist internal air into the cavity. Use of external sarking for walls also helps to limit air movement across the wall.

Membranes that are water vapour permeable while still being impermeable to liquid water can assist in providing for water vapour egress from the construction.

The use of absorbent building materials also influences moisture movement and the consequences of any condensation that may form. Some materials such as wood and brick have a capacity to absorb and store moisture while other materials such as steel and glass do not. For example, in a bathroom, although beads of condensation form on the surface of the mirror, the window or plastic shower curtain, they do not form on the surface of the timber frame around the mirror, the toilet paper or textile curtains. Although at the same surface temperature the latter materials are absorbing moisture.

Absorbent materials can store moisture and hold condensation until such time that drying conditions prevail, which can protect other materials from becoming wet. Of course the absorbent material must be able to accommodate higher moisture levels without damage. Use of absorbent building materials can also result in locked in construction moisture, which may create issues if drying is impeded.

2.5 The influence of climatic conditions

The direction of the predominant flow of moisture vapour can be determined from an understanding of the vapour pressure conditions inside and outside a building.

Vapour pressure is related to the temperature of the air and the amount of moisture contained in the air. For the same relative humidity, higher temperatures result in higher vapour pressure. For the same temperature, higher relative humidity results in higher vapour pressure.

Generally the direction of vapour flow can be classified as follows:

Cold climates: The vapour pressure is usually lower outside due to the fact that indoor temperatures are well above those outside. In addition to this we tend to generate moisture within our homes, which often results in higher indoor vapour pressure. Therefore in cold climates the vapour flow is typically outward.

Temperate climates: Other than during seasonal extremes, the vapour pressure difference is not great because the difference between indoor and outdoor temperatures and vapour pressure levels is less.

Tropical climates: Tropical climates typically have high outdoor temperatures combined with high relative humidity, resulting in high outdoor vapour pressure. This creates a slight inward vapour flow. For an air-conditioned building in a tropical climate the indoor vapour pressure is reduced as both the indoor temperature and humidity is reduced. This results in a large vapour pressure difference, creating a much greater inward vapour flow.

2.6 The influence of local climate

Understanding the local climate that the building is exposed to is important to ensure that appropriate principles are applied and that suitable climate data is used in any risk assessment that is undertaken.

The BCA energy efficiency measures divide Australia into eight distinct climatic zones – see Figure 2.3. The broad principles to control condensation in each of these zones will often be common. However, while each climatic zone has similar temperatures; the humidity and rainfall that exists within each of the zones can create a variety of sub-climates. In addition, many factors may influence the local micro climate to which the building is exposed. Examples of local factors include: exposure to weather, shade, flooding, cyclones, vegetation, orientation, proximity to water, concentrations of groundwater, elevation and terrain.

In addition to having an understanding of the local outdoor environment some buildings have indoor environments that require special consideration. Examples of special use buildings include, refrigerated buildings, buildings containing pools or spas, museums, etc.

Figure 2.3 BCA Australian Climatic Zones

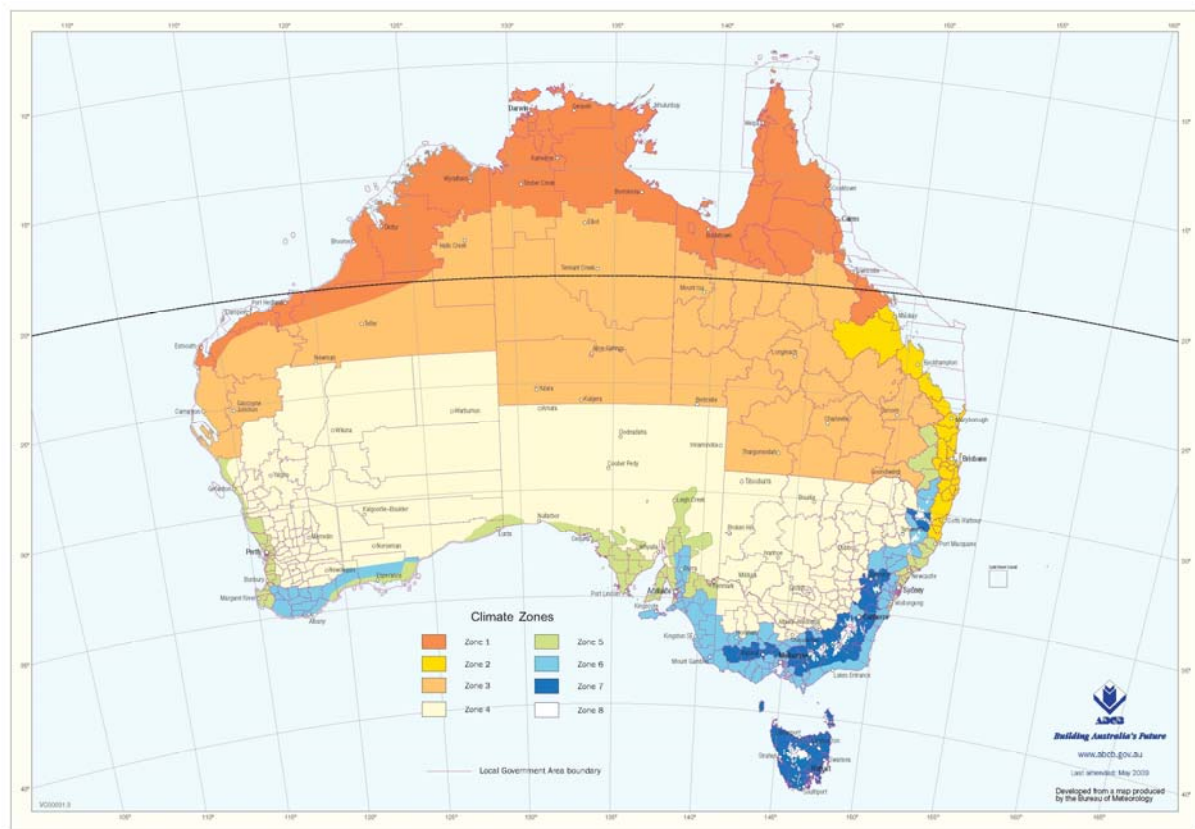

Note: The current version of the BCA climate zone map can be obtained from <http://www.abcb.gov.au>. Individual state and territory maps which are more detailed are also available.

2.7 Key Moisture Management Principle

While the focus of this handbook is upon designing to manage condensation, an understanding of the broad principles of moisture management is useful. The key principle of moisture management in building cavities is to:

- Design to keep moisture out of the building envelope, but when it does get in – and it is likely it will get in, allow for it to escape.

Not adhering to the latter part of this principle is the cause of many moisture related building problems.



The premise is often that a vapour barrier (or impermeable cladding) will provide adequate protection. However, once moisture gets in behind a vapour barrier, the barrier acts to trap the moisture, stopping the building fabric from drying and leading to decay.

Inappropriately placed materials acting as cold side vapour barriers also contribute to moisture related building problems.

As a result of previous experience New Zealand now advocates the following principles to control external moisture:

- Deflection: shed water by a cladding system, including deflecting devices such as eaves and 'weathering' deflectors
- Drainage: a back-up system to direct water that may bypass the cladding back to the outside
- Drying: remove remaining moisture by ventilation or diffusion
- Durability: use materials with appropriate durability within the life expectancy of the building.

Chapter 3 Consequences of Condensation

This chapter discusses how the failure to consider condensation within the built environment can have serious consequences arising from both surface and interstitial condensation. Some of those consequences include:

- visible and hidden fungus and mould growth
- sick building syndrome leading to serious health problems
- timber decay
- phantom leaks
- saturation of insulation and loss of insulation effectiveness
- corrosion
- loss of structural integrity
- health and safety risk arising from slippery floors

3.1 Surface Condensation

Because surface condensation is visible, occupants can take action to deal with issues by mopping up the moisture or taking preventative measures such as keeping surfaces above dew point, improving ventilation or introducing drainage to deal with the moisture.

Excessive surface condensation can however, have more serious consequences, for example:

- When condensate on the underside of ceilings, exposed metal roofing or purlins drips, it can, for example, cause problems in food processing factories and in laboratories or buildings where electrical equipment or chemicals are either being used or manufactured.
- Where there is cold bridging, condensation is inclined to form, either on the exterior or interior finish, which then attracts dust and this may lead to pattern staining impacting on the aesthetics of the building.
- Floors, particularly those constructed with a high thermal mass, can remain cold for a period of time following a change to warmer, more humid weather, diurnal variations or when heating is turned on in the morning. This can lead to condensation forming on non absorbent floor surfaces. This increases the risk of accidents from slipping in buildings such as factories, offices, aged care and medical facilities.
- Excessive condensate running on the inside of glazing that is not dealt with by drainage or drying can lead to deterioration of the window frame and floor surfaces. Such problems are particularly common with skylights.

Surface condensation problems can also be a warning that moisture levels are excessively high within the building, and that ventilation is insufficient. This is a good indicator that there could also be problems in the building envelope that are developing unseen.

3.2 Interstitial Condensation

Interstitial condensation within the building envelope can have serious consequences as it can build up hidden from view of the occupants and thus go undetected for a long period, by which time the severity of the problem will have increased.

Interstitial condensation usually occurs in a location that is difficult to access. Remediation and rectification often require the removal of either the exterior or interior lining which can be complex, expensive and inconvenient for the occupants.

The longer problems are left unchecked, the more likely they will have structural implications in addition to cosmetic and mould-related problems.

3.3 Structural problems

Hygroscopic materials such as timber have a capacity to absorb and release moisture depending on the environment in which they are situated. Condensation will very rarely be seen dripping from timber because of its capacity to absorb moisture. However, if for prolonged periods the moisture content of timber reaches over around 18-20% (by mass) it can become susceptible to decay and fungal attack and impact on the structural integrity of the building.

When condensation builds up for an extended period of time it can cause corrosion of metal framing, sheeting, foil sarking or any metal components that have not been designed to tolerate such moisture.

Condensation is less likely to remain on metal surfaces for an extended period of time before diurnal variations (daily fluctuations of temperature and humidity) let it dry out. However because metals, glazing and some plastics are non-absorbent the condensation that forms on them will either drip or run off elsewhere and collect on other absorbent materials, such as plasterboard ceilings or in locations where moisture can accumulate in larger volumes.

An example is where condensation forms on the inside face of a sarking and runs down, collecting in larger concentrations at noggins or at the bottom plate where it is unable to dry out before damage becomes critical or irreversible.

3.4 Release of salts and chemicals

Many building materials are manufactured with salts and chemical preservatives and remain relatively inert when dry. During construction in coastal environments, building materials may also become coated with salt before the building is enclosed.

In a high humidity environment or when exposed to condensate, materials can release these salts and chemicals with damaging consequences for the occupants, contents and furnishings of the building, and other adjacent materials such as fixings that may corrode when exposed to such salts and chemicals

3.5 Reduced effectiveness of insulation materials

Where condensate accumulates in insulation materials, even at levels as low as 1% by volume, it can significantly reduce the thermal resistance of the insulation, as illustrated by Figure 3.1.³ This is because the air gaps in porous insulation are replaced by water, which is a better conductor of heat.

Figure 3.1

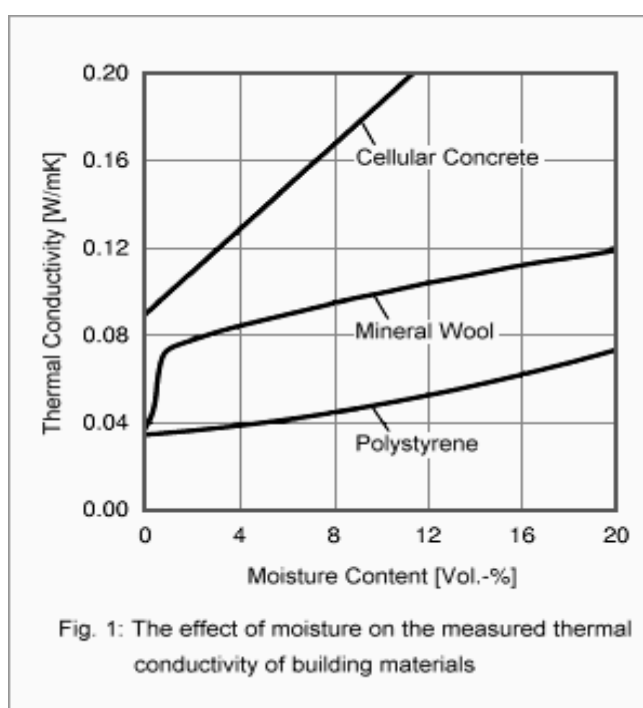

The closed cell structure of some foam insulation materials such as extruded polystyrene, phenolic, polyisocyanurate (PIR) and polyurethane (PUR) insulation are less susceptible to moisture and water vapour ingress and so are less prone to loss of insulative performance. Open cell materials such as mineral wool and expanded polystyrene are more at risk of loss of thermal resistance.

³ Cammerer, J. und Achtziger, J.: Einfluß des Feuchtegehaltes auf die Wärmeleitfähigkeit von Bau- und Dämmstoffen. Bericht zu BmBau Forschungsvorhaben BI 5-800883-4, 1984.

If low emissivity radiant barriers are utilized, even a thin film of condensation will mean the radiant barrier then behaves as if it has a high emissivity coating. This is usually transitory and when the condensate clears the reflective properties are restored. Bare aluminium foil radiant barriers that are exposed to degradation from condensation or corrosive environments experienced in coastal locations or high humidity buildings such as swimming pools where chlorine gas is present, are at risk of losing long term in-situ performance as radiant or vapour barriers.

3.6 Phantom or Ghost Leaks

When moisture unexpectedly turns up in a building there is a tendency to assume it is a leak. However, leaks are not always to blame and problems may be the result of condensation. When investigating phantom leaks it is worth noting that condensation may be forming in one location and dripping or running to another location where it later becomes apparent to the occupier. If the appearance of leaks is seasonal and not directly correlated to periods of heavy rainfall, this is a sign that condensation may be the cause.

3.7 Sick building syndrome and mould

Sick building syndrome is a term used to describe a range of symptoms, such as respiratory difficulties, itchy eyes, skin rashes, and nasal allergy, which may be triggered when the sufferer spends time in a particular building.

One of the key contributory factors behind cases of sick building syndrome is moisture and related mould growth.

Mould growth requires all five of the following conditions.

1. Infestation, i.e., mould spores to germinate
2. Nutrients (mostly cellulose and starch, but also dirt and dust)
3. Temperature (typically in the range of 5 to 50 °C)
4. Moisture (surface relative humidity of over 75 to 80%)
5. Oxygen (freely available above the waterline in all buildings)

As it is not feasible to eliminate oxygen or mould spores from the built environment and since most building materials are a good source of nutrients, building designers need to concentrate on managing the controllable factors of temperature and moisture. Figure 3.2 below shows how the dual factors of temperature and relative humidity impact on the time taken for mould to germinate and the speed at which it can grow.

Figure 3.2 Temperature-Time-Moisture relationship for *Aspergillus restrictus* on a high nutrient substrate ⁴

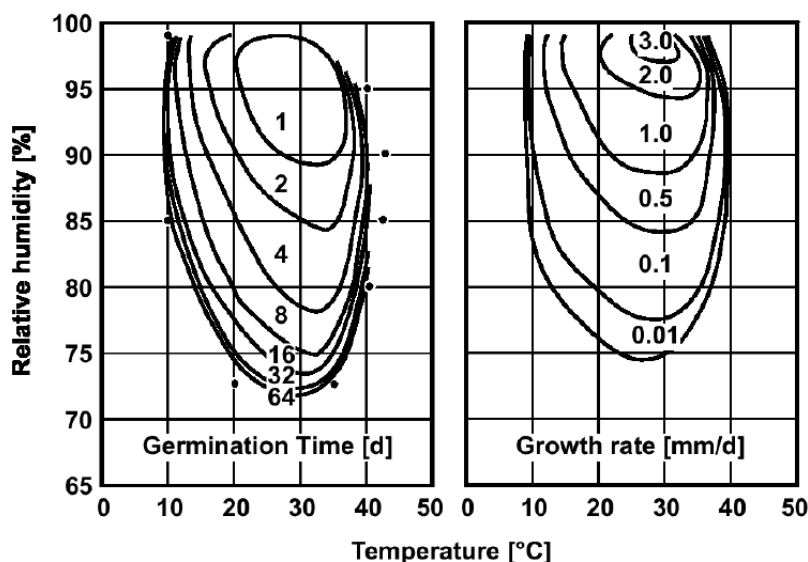

Because the exterior skin of the building envelope is exposed to moisture due to rain, outer claddings are usually designed to shed rather than absorb moisture. If the exterior skin is well maintained the inside of the building envelope should be less exposed to moisture from outside the building.

However, the micro environment of the building envelope is more likely to be conducive to mould growth because it is generally a warmer environment, and because building materials and dust in this location offer a rich and plentiful source of nutrients for mould growth. Due to gaps and penetrations in the interior skin there is usually a good path for the transfer of mould spores from inside the building envelope to the occupied space where they can reach a level of concentration that then impacts on the health of the occupants.

In Australia to date, mould remediation has only been considered by insurance companies if mould contamination is the resultant damage of an escape of water or water intrusion that was covered under the terms of the policy. Mould resulting from poor building design or rising damp is generally excluded from cover.⁵

⁴ Source: Krus, M., Sedlbauer, K., Zillig, W., Kuenzel, H., "A New Model for Mould Prediction and its Application on a Test Roof", Proc. Of Current Problems of Building Physics in the Rural Building, Cracow, Poland, Nov. 2001.

⁵ Source: Dr. Peter Kemp & Dr. Heike Neumeister-Kemp, "What's all the fuss about mould lately?"

Two fungi that become prevalent, where construction timbers become wet, are *Trichoderma viride* and *T. harzianum* which can affect the health of occupants and are destructive. A contributing factor seems to be treated structural timbers that are being wrapped in plastic at the factory and sweating during storage. Many believe that “treated” means anti-fungal, but chemicals used to treat timber (AS1604-1997) are not anti-fungal.⁶

A comprehensive *Mould Control Practice Guide* has been published by the Ontario Association of Architects to aid understanding of the potential threats of mould in the built environment and offers suggestions as to how to help avoid or minimize it, and provides insight into how best to mitigate a mould infestation.⁷

3.8 Dimensional changes

Many building materials will change their dimensions when they absorb moisture. Dimensional changes that were not accounted for at the design stage accompanied by uneven rates of wetting and drying of materials leads to bowing and a strain on adjacent materials. In the case of exterior claddings this will put the building at greater risk of moisture penetration thus exacerbating the problem.

3.9 Electrical failures

Condensation in the building envelope can cause electrical failure and may be an electrocution risk, (particularly in proximity to foil sarking or moist bulk insulation) around electrical fixtures and any cabling inside the building that is generally are not protected from moisture.

⁶ Source: Dr. Peter Kemp & Dr. Heike Neumeister-Kemp, “What’s all the fuss about mould lately?”

⁷ Ontario Association of Architects, “OAA Mould Control Practice Guide”, September 2003

Chapter 4 Risk Assessment

This chapter provides a checklist of factors to consider when assessing the risk of condensation and discusses approaches to conducting condensation risk analysis.

There are a large number of factors that need to be considered in assessing and managing condensation risk. The key factors can be categorised as:

- Exterior environment - macro and local micro climates
- Interior environment - building use, intended level of occupancy and conditioning methods
- The building envelope - position, thickness and material properties of building materials used, in particular insulation, vapour barriers and vapour permeable (breathable) membranes e.g. as required by the BCA Damp and Weatherproofing, Energy Efficiency and Bushfire Construction requirements
- Ventilation - the adequacy of mechanical and passive ventilation, both inside the building and within cavities and the roof space
- The frequency of condensation risk.

There are a number of tools that can be used by building designers or engineers to evaluate condensation risk. Many user-friendly software models have been developed overseas with embedded material properties and climate data. Although not all software have been fully localised for Australia, most material properties are generic, detailed climate data is freely available and the same psychrometric principles apply.

Where the designer is in doubt, it is highly recommended to conduct or commission a condensation risk analysis in order to make an assessment of the risks and then decide what measures, if any, are required to mitigate the risk.

4.1 The Risk Analysis Checklist

External environment in the location of the building

Exterior climate data is crucial to understanding whether the direction of the vapour drive is either internal to external or vice versa. External climate is a determinant of the temperature of all building materials. The key external environmental data required is temperature and relative humidity (or dew point temperatures). To get a better understanding of the risks, it is worthwhile considering mean maximums and minimums as well as worst case scenarios.

<p>General advice is included in Chapter 5 for the very broad cold, temperate and tropical climate types. However within these broad climate types there are other factors that need to be considered.</p>	
<p>Local climatic data</p> <p>Within broad climate zones there can be wide variations. For example, coastal locations generally have higher minimum temperatures but also higher relative humidity. At higher altitudes minimum temperatures will be lower, all other things being equal.</p>	
<p>Site-specific considerations</p> <p>To be effective, strategies need to be sensitive to site-specific factors. For example, a building in a hollow, near a lake, or one sheltered from prevailing winds by other buildings will be harder to design to ensure adequate roof space ventilation.</p> <p>Some sites with poor drainage and high soil moisture content can correlate to a higher interior relative humidity, particularly without adequate damp proof protection.</p> <p>Roofs and walls that are in shade for longer periods of the day such as south facing corners, will be at lower temperatures for longer periods than those with high solar exposure.</p>	
<p>Seasonal considerations</p> <p>Most locations will be subject to differences in seasonal climates. In some locations the dominant direction of vapour drive can change between seasons. When assessing condensation risk, the extremes of summer and winter conditions should be considered. Ideally a design should reduce the risk in both extremes, however it may be necessary to determine, on balance, in which season the risk is greater.</p> <p>In residential construction for example, the dominant risk in cold and temperate climate zones is in winter, rather than in summer.</p> <p>The dominant risk of condensation for residential construction in the warm arid and humid BCA climate zones 1 to 3 is during the summer months, when weather in these zones is influenced by the wet season in the tropics. Humidity is much higher during this period and although air temperatures are high, radiation to the night sky results in roof temperatures falling well below dew</p>	

<p>point.</p>	
<p>Impact of diurnal changes</p> <p>Residential buildings are most likely to be occupied in the evening, at night and early in the morning when most moisture is being created by occupants through cooking, bathing, breathing etc. This coincides with lowest external temperatures and explains why condensation on the inside of windows is often obvious early in the morning.</p> <p>With air conditioned buildings in tropical climates the dominant vapour drive is from the exterior to the interior, but this can reverse on clear nights when night sky radiation cooling drops roof temperatures below dew point. Temperatures of walls do not fall as much due to their lesser exposure to the night sky.</p>	
<p>Where to find more information?</p> <p>The Bureau of Meteorology (www.bom.gov.au) is an excellent source of detailed local climate data collected over many years. Summarised data is also available from the Australian Institute of Refrigeration Air Conditioning and Heating (www.airah.org).</p>	
<p>Interior environment</p>	
<p>Internal environmental data is the other requirement for understanding if the direction of the vapour drive is either from internal to external or vice versa. The interior environment is the key determinant of the temperature of all building materials on the interior side of any thermal insulation.</p> <p>Variable human factors need to be anticipated at the design stage. How occupants make use of air-conditioning and heating, their lifestyles and willingness to open windows can have significant impacts on the interior environments. As these factors are beyond the control of the building designer it is worthwhile considering high risk condensation scenarios.</p>	
<p>Anticipated building use</p> <p>Buildings that are likely to have higher interior relative humidity will be at greater risk of condensation.</p> <p>In order of risk, British Standard BS 5250: 2002 Code of practice for control of condensation in buildings splits building use into 5 categories:</p> <ol style="list-style-type: none"> 1. Storage areas 2. Offices and shops 3. Dwelling with low occupancy 	

<p>4. Dwelling with high occupancy, sports halls, kitchens, canteens and buildings heated with unflued gas heaters</p> <p>5. Special buildings. e.g. laundry, brewery, swimming pools</p> <p>For the purpose of condensation risk calculation, the standard provides values for internal relative humidity which are listed in Appendix C.</p> <p>In buildings such as museums, libraries, hospitals, cold stores, ice rinks and aquatic centres, the interior conditions will be set and maintained at a certain level.</p>	
<p>Conditioning Methods</p> <p>The methods used to maintain comfort in a building will influence both the internal temperature and relative humidity (or dew point temperature).</p> <p>For example, an unflued gas heater can give off 2 litres of water vapour for every litre of natural gas burnt thus increasing condensation risk.</p> <p>American Society of Heating, Refrigeration and Air-Conditioning Engineers (ASHRAE) Standard 55-2010 Thermal Environmental Conditions for Human Occupancy now recommends dehumidification design for an indoor dew point temperature of 13°C or less.</p> <p>If the interior is pressurized, air leakage, and the water vapour this carries through interior linings, will be at higher volumes.</p> <p>Most residential air conditioners in tropical regions are undersized due to underestimation of the ventilation air latent energy load. This practice means that while they may get the indoor air temperatures down they have less effect on the humidity. In Cairns the latent load is approximately 60% of the total cooling load. This means that indoor air is around 24 degrees and 90% RH. Occupants do not notice this high humidity thermally as humidity has little influence on thermal comfort in the 22-26 deg operative temperature range. After all the mould problems in the humid tropics in the USA, ASHRAE now recommends A/C design for an indoor dew point temperature of 13°C or less. At an indoor 27°C the relative humidity would need to be 42% to achieve a dew point temperature of 13°C.</p>	

Where to find more information?

In addition to the classifications in BS 5250: 2002 included in Appendix C, other internal humidity classifications can be found in EN15026⁸, ISO 13788:2001⁹ and ASHRAE standard 160P¹⁰

The Building Envelope

The properties and placement of materials used to create the building envelope will determine throughout the year, temperature and dew point profiles through the building fabric. Detailed information on approaches to the location of materials such as vapour barriers, vapour permeable (breathable) membranes and insulation can be found in Chapter 5.

Physical properties of materials used in the construction

The key material properties required for a basic steady state condensation risk analysis described in Section 4.2.3 below are:

- thermal conductivity and infra-red emissivity
- water vapour resistivity, (or the water vapour transmission rate (WVTR), it's reciprocal)

An understanding of a material's capacity to store moisture at safe levels is also an important consideration, as depending on where and for how long it occurs, not all condensation within the building envelope is problematic.

When assessing the condensation risk of systems incorporating reflective insulation, it is important to study the temperature profile for the particular system (with climate data for when condensation is considered likely) and note that reflective insulation thermal resistance is a property of the air space, which sets its bounding surface temperatures and likelihood of condensation.

Importantly, vapour impermeable reflective insulating surfaces should be on the warm side of a cavity to prevent condensation, i.e. the vapour barrier must operate above the dew point of adjacent air. If that is not possible, the condensation that occurs must be free to drain without causing damage.

8 EN 15026:2007 Hygrothermal Performance Of Building Components And Building Elements - Assessment Of Moisture Transfer By Numerical Simulation

9 ISO 13788:2001 Hygrothermal performance of building components and building elements -- Internal surface temperature to avoid critical surface humidity and interstitial condensation -- Calculation methods

10 ASHRAE Standard 160P--criteria for moisture control design analysis in buildings

<p>Where to find more information?</p> <p>The thermal conductivity and vapour resistance values for more common building materials can be found in Appendix C. Other useful sources for this information are AIRAH, ASHRAE Handbook – Fundamentals Chapters 23 and 25, Building Science textbooks, and test data supplied by manufacturers.</p> <p>For example, all pliable building membranes tested for compliance to AS/NZS 4200.1 Pliable Building Membranes: Materials will have been tested for vapour resistivity. Insulation materials likewise will have been tested for thermal conductivity. Most calculation software also will include a database of common material properties.</p>	
<p>Ventilation</p>	
<p>One principle of good design for natural ventilation is to 'build tight — ventilate right'. A building cannot be 'too tight', but it can be under-ventilated.</p> <p>The type and location of ventilation can be a complex issue requiring consideration of a number of factors:</p> <ul style="list-style-type: none"> • ensuring a suitable air-speed rate to provide comfort for occupants • ensuring suitable air change rate to prevent build up of volatile organic compounds (VOCs) • ventilation of water vapour from the interior and the cavities within the building envelope • suitability of the building's conditioning system • the energy efficiency needs of the building 	
<p>Interior Ventilation</p> <p>The level and location of interior ventilation can influence the relative humidity of the interior environment and also the amount of water vapour that consequently enters the building envelope.</p> <p>It is important to distinguish between designed passive ventilation, mechanical ventilation and unintended ventilation as a result of poor building air tightness.</p>	
<p>Ventilation within wall cavities and the roof space</p> <p>Where condensation is likely to form within the building envelope, effective ventilation can reduce condensation risk and aid drying.</p>	

If water vapour laden air is removed from the building it is important to consider where the replacement air comes from.

For example, when roof vents are used to extract the water vapour from the roof space, it must be replaced by exterior air which can pick up moisture and remove it at a rate greater than the moisture accumulation. Drawing conditioned replacement air from inside the building through ceiling penetrations is not likely to be effective and impacts on energy efficiency.

If ventilation is introducing air at a different temperature, then this will also impact on the temperature profile through the building envelope and also the energy required to heat or cool replacement air.

When renovating buildings, efforts to improve air tightness that fail to maintain adequate ventilation will impact on condensation risk.

Where to find more information?

There are no standards in Australia that offer guidance on what is suitable ventilation of wall cavities and the roof space. The BCA does include some guidance for roof space ventilation but this is for the purpose of determining the effective insulation value rather than reducing condensation risk.

For detailed guidance on roof space ventilation in cold to mild temperate climates, BS 5250:2002 provides comprehensive guidance on the minimum size and location of ventilation.

4.2 Condensation Risk Calculation Methods

4.2.1 Surface Condensation

British Standard BS EN ISO 13788:2002 Hygrothermal performance of building components and building elements. Internal surface temperature to avoid critical surface humidity and interstitial condensation. Calculation methods contains a method for calculating the internal surface temperature of the building fabric below which mould growth is likely, given the internal temperature and relative humidity. The parameters considered to determine the risk of surface condensation and consequent mould growth are summarized as:

1. External temperature and relative humidity
2. The thermal resistance of the building envelope taking into account thermal bridges
3. Internal temperature and relative humidity paying particular attention to moisture sources

To avoid mould growth the relative humidity at the surface should not remain above 80% for several days.¹¹ Methods for addressing thermal bridging may be found in AS/NZS 4859.1 2002 Materials for the thermal insulation of buildings – General criteria and technical provisions.

4.2.2 Interstitial Condensation

Two main methods used in the calculation of interstitial condensation risk are **steady state** and **transient**, each of which has their own advantages and limitations.

4.2.3 Steady State Methods

Calculation methods that assume one-dimensional, steady-state conditions, often referred to as “Glaser methods,” consider diffusion of water vapour through building materials and are used to calculate the maximum amount of accumulated moisture due to interstitial condensation within a structural element.

Such methods are not without limitations, however, by making these calculations and applying some practical knowledge, it is possible to get a reasonable indication of the magnitude of any condensation risk. The advantage of the Glaser method is that it is simple enough to permit calculations to be done manually and can be done in conjunction with calculations to determine the temperature profile of a building element.

One method is contained in BS EN ISO 13788:2002 and this method has been adopted by a number of commercially available software packages in Europe.

The steady state method should be regarded as an assessment tool, suitable for comparing different constructions and assessing the effects of modifications rather than as an accurate prediction tool.¹² However, the results of a simple steady state calculation should still be used as one tool in the analysis of any moisture related issues. It is useful for predicting the temperature of layers of the building envelope and the dew point temperature surrounding that layer. If a layer is always safely warmer than the dew point and no moisture has been trapped between impermeable layers, it is a good indication that there will be no condensation problem.

The limitations of the steady state calculation methods are covered in the next section on transient methods.

¹¹ BS 5250:2002 (Annex D) Code of Practice for control of condensation in buildings

¹² BS 5250:2002 Code of Practice for control of condensation in buildings

Appendix B includes three examples of a steady state condensation risk analysis for typical brick veneer construction in colder climate zones. A comparison of these three condensation risk analysis for almost identical designs, highlights the importance of knowing and specifying the maximum vapour resistance of the sarking and also that the placement of insulation and reflective air spaces can impact on where dew point occurs.

4.2.4 Transient Methods

The basic steady state models do not take into account factors considered by more complex transient calculations that model dynamic changes within the construction throughout the year at intervals as short as one hour, depending on availability of climate data. There are transient models that consider some or all of the following factors;

- any moisture that remains in the structure from the construction stage that has not dried out
- the variation in material properties such as thermal conductivity that depend on moisture content
- latent heat that is released/absorbed by condensation/evaporation.
- capillary suction and liquid moisture transfer within materials
- air movement through or within the building elements through cracks and in air spaces such as cavities and roof spaces
- the hygroscopic capacity of materials
- boundary conditions that are not constant over a month and change on a daily and hourly basis
- the effects of solar and long-wave radiation
- the drying out of built-in moisture.

4.3 References/Further reading

1. ASHRAE, ASHRAE Handbook Fundamentals, SI Edition, American Society of Heating
2. Refrigeration and Air-Conditioning Engineers, Inc. Atlanta 2009, Chapter 26.



Chapter 5 Designing to Avoid Condensation

This chapter discusses design strategies for mitigating condensation in roofs, walls and floors with reference to specific climate zones and their resulting propensity for condensation issues.

5.1 Overview

It is important to consider condensation principles and or conduct a condensation risk assessment (see Chapter 4) in order to determine where and when condensation is most likely occur, to what extent this builds up over time and the impact of the moisture either on the surface or stored within the material. For example, condensation that occurs in a vented and drained cavity external to the structure may cause no harm but if the same amount of condensation were to be stored within timber for an extended period of time, thereby raising its moisture content above a certain level, it may compromise its structural integrity.

As established in Chapter 2, condensation will form on any surface when it is below the dew point temperature of the surrounding air. In order to avoid condensation the surface temperature must be increased or the moisture in the surrounding air must be reduced. Generally small quantities of condensation are tolerable provided it can dry without causing damage. If the environment remains moist for a substantial period of time degradation may occur through fungal growth, mould, timber rot, corrosion, etc (see Chapter 3).

General observations may be made about surfaces that are prone to condensation in different climate zones.

Cold climates: The temperature is usually lower outside and therefore it is condensation on the outer layers that may cause an issue. Generally the colder the environment the more critical this condition can be. In addition, if the outdoor humidity is high then drying conditions will be reduced. To minimise the effect of warm moist internal air diffusing through the linings and condensing on the cold outer layers a membrane that can act as a vapour barrier and air barrier should be located near the internal lining of the wall.

Temperate climates: The difference between indoor and outdoor temperatures is not as large as for a cold climate. For this reason the need for a vapour barrier is reduced. Generally on sun exposed surfaces or in the summer the internal lining will be cooler during the day while the external lining will be cooler overnight.

Tropical climates: From a surface temperature perspective the tropical climate is similar to that of a warm climate. The internal and external surface temperatures are similar with the exception that the nighttime surface temperatures also remain high, however humidity is often high.

Metal roofs however, on clear still nights can fall to 5-8°C below surrounding air temperature due to radiant heat loss to the night sky, exacerbating condensation risk. The low roof temperature combined with high humidity in tropical climates results in condensation. Bare metal roofs therefore benefit from a vapour barrier installed beneath protecting the underside of the metal roof. Protection can be provided through measures such as installing, beneath the metal roof, a draped pliable membrane or foil-faced insulation blanket with the foil facing upward, see Chapter 5.3.1.

If the building is consistently cooled, e.g. through regular air-conditioning, the internal surface of the internal linings may drop below the dew point of moist external air that may diffuse or leak through the external linings causing condensation. In this case, a vapour barrier creating an airtight layer located toward the outer layers of the wall would be useful. However if this vapour barrier leaks serious condensation may occur.

The three climate categories above, cool, temperate and tropical, can be approximated to the climate zones associated with the BCA climate zone map (see Chapter 2, Figure 2.3), noting some overlap, as follows:

BCA Climate		Zone	Approximations
Description			
High humid summer, warm winter	1	Tropical	
Warm humid summer, mild winter	2		
Hot dry summer, warm winter	3	Temperate	
Warm temperate	5		
Hot dry summer, cool winter	4		
Mild temperate	6	Cold	
Cool temperate	7		
Alpine	8		

In each of these climates the risk of condensation is increased by water vapour generated by indoor activities. Water vapour generated by clothes driers, hot showers etc. is likely to condense on indoor surfaces and possibly inside wall and ceiling cavities unless the moisture-laden air is exhausted directly outdoors, as recommended in Chapter 5.2.3. Exhausting moisture-laden air into building cavities, such as roof spaces, may result in significant condensation and associated damage from termites, dampness and mould growth.

The remainder of this chapter provides more detail about building materials and strategies that can help mitigate condensation. It also provides specific guidance for roofs, walls and floors.

5.2 General Principles

5.2.1 Building membranes

The most common building membrane is sarking. In accordance with AS/NZS 4200.1, a sarking membrane is a material intended to collect and discharge any water that may penetrate a building element. It is important to understand the attributes of the sarking to ensure that it functions as intended. Some typical additional functions of sarking are:

- As a vapour barrier
- As a vapour permeable (breathable) membrane
- To absorb or collect and release moisture to deal with intermittent condensation or high moisture levels
- As an airtight layer - convection barrier
- To hold insulation in place
- As insulation, by its placement creating a reflective still air space
- As a barrier to inhibit spread of fire

Some of these functions are not compatible so the designer needs to prioritise them to ensure that there are no detrimental impacts from the selection of the material.

There are 3 main types of pliable building membrane with respect to controlling flow of water and water vapour;

- 1) Vapour barriers - a membrane that is intended to restrict the transmission of water vapour, often referred to as a vapour retarder or vapour control layer (VCL), and often comprises plain Reflective Foil Insulation (RFL).
- 2) Vapour permeable or breathable – A membrane intended to allow the transmission of water vapour and/or liquid water.
- 3) Smart vapour retarder – a membrane that changes from restricting to allowing the transmission of water vapour depending upon the temperature or relative humidity present.

Understanding temperatures, the predominant direction of vapour flow and the drying conditions that exist for a particular building will assist in selecting and positioning appropriate sarking and other building membranes.

For most buildings the conditions are clear, so too are the general principles.

In cold climates, such as BCA climate zones 7 and 8, there is a strong tendency for outward migration of moisture. Building membranes installed on the cold external side of insulation should be a vapour permeable (breathable) membrane. Building membranes installed on the warm internal side of insulation should be a vapour barrier.

The following is an extract from an Experimental Building Station report on the use of pliable membranes in cold climates.

“Where the average minimum winter temperature is about 5°C or lower, the condensation problem is likely to be acute, and calls for the use of an effective vapour barrier at the warm (indoor) side of the construction, to impede the entry of water vapour into the construction.

Water vapour that might nevertheless penetrate into the construction should be free to reach outdoors. Hence the sarking applied behind weatherboards could be regarded in this case as a vapour barrier in the wrong position. Where both treatments are used, the sarking, as fixed, should be more permeable to water vapour than the vapour barrier.”¹³

In warm humid coastal and tropical climates such as BCA climate zones 1, 2 and 3, buildings without air conditioning should be constructed without vapour barriers except under roofs and concrete floors.

Walls in air conditioned houses should not have vapour barriers. Instead vapour permeable membranes should be used, where needed, to allow maximum movement of water vapour in both directions, in and out. Materials closer to the interior should be more permeable than those nearer the external surface of the wall.

Temperate and inland BCA climate zones 2, 3, 5 and 6 typically have lower vapour pressure difference between indoors and outdoors and have conditions whereby the direction of moisture flow cycles. In these climate zones the preference is to use vapour permeable membranes to avoid creating a seasonal moisture trap and allow drying in either direction.

The requirements for the inland BCA climate zone 4 have particular cold winters that can create high outward moisture flow, whilst the summers are warm but often dry. Therefore the principles for a cold climate prevail.

Building membranes that act as vapour barriers should be used with caution, and only where their function is clear, otherwise they can become moisture traps keeping building materials wet and causing permanent damage. Vapour permeable (breathable) membranes are designed to provide minimum resistance to water vapour, are less likely to fall below dew point and are much more forgiving in allowing the building fabric to dry should moisture generate within the building fabric.

13 Drysdale J W, *Designing houses for Australian climates. Bulletin No 6, 3rd Edition Experimental Building Station, 1975.*

Note: Most building codes and standards regarding vapour barriers have been developed for cold to temperate climates in Europe the UK and Canada. The only major country with a comparable range of climates to Australia, extending into tropical regions, is the USA. ASHRAE has recently proposed a USA building code for vapour barriers (Lstiburek, 2004).¹⁴

5.2.2 Insulation

The location of insulation within a building fabric will dictate the predominant temperature to which materials within the building fabric will be subject. For instance, in cold climates, materials on the external side of the insulation will be cooler, and on the internal side warmer. This will dictate the preferred function of the membranes that make up the building fabric. See Section 5.2.1.

The thermal resistance of insulation influences the surface temperature of internal linings. In cold climates increasing the insulation level will keep the internal lining warmer, making it less prone to condensation, however the internal lining will also become more prone to patterned staining (ghosting) as a result of convective or conductive thermal bridging should either detailing or installation be poor (see Chapter 3).

The thermal resistance of the insulation will also influence the temperatures within the building fabric. In cold climates, for an insulated wall with external sarking, both the external cavity and sarking will become colder and more prone to condensation as the insulation level increases, see Figure 5.1. The condensation risk upon the sarking can be reduced by using low emittance (reflective) exterior sarking, which elevates its surface temperature.

¹⁴ Lstiburek, J. (2004) *Understanding vapor barriers*, ASHRAE Journal, Aug, pp. 40-50.

Figure 5.1

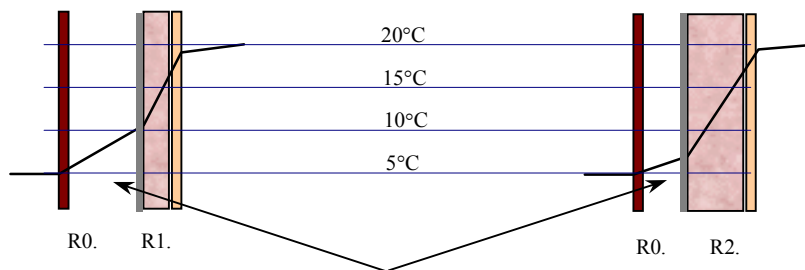

Increasing insulation leads to

- a cooler outer cavity increasing the potential for condensation to form on outer surfaces.
- cooler sarking increasing the potential for condensation to form on the inner surface against the insulation, which can cause problems in cold and cool temperate climates if the sarking also has the properties of a vapour barrier and is not sufficiently vapour permeable.

Other factors that insulation may impact with regard to moisture performance include:

- its ability to absorb and release moisture, which may aid in dealing with intermittent condensation
- its vapour resistance, which will influence the flow of water vapour through the building fabric
- its ability to control air movement, which will also influence the transport of water vapour through the building fabric
- the way it is detailed to avoid thermal bridging (see Section 5.2.4).

5.2.3 Ventilation and air movement strategies

Ventilation and air movement can be used to reduce both the likelihood and amount of condensation forming on surfaces:

- Air movement can increase the temperature of a surface.
- Air is viscous that is it tends to stick to surfaces. The viscosity of the air results in a thin air film attached to surfaces. If the stagnant air film is disturbed by air movement the temperature of the chilled air adjacent to the cold surface can be raised above dew point temperature. (See Case Studies in Appendix A).
- Ventilation of outdoor air into a room can be used to avoid condensation by introducing drier outdoor air (lower vapour pressure /dew point) if moist air is exhausted through windows or vents and not into wall cavities or roof space.

- Ventilation of outdoor air can be particularly beneficial in dealing with persistent or intermittent high indoor moisture levels causing condensation.
- Exhaust fans can remove water vapour generated in a room by exhausting indoor air to the outdoors.

In well-sealed air-conditioned space, this requires that the air exhausted from bathrooms, laundries, toilets etc. be replaced with make-up air. This make-up air drawn from outdoors needs to be preconditioned to indoor temperature and humidity conditions before it is mixed with the main body of circulating air in the system. If this is not done then general humidity control within the building can be compromised.

Condensation can be reduced by exhaust fans located as close as possible to the water vapour source. Care should be taken as to where the exhaust air is released. If the warm moist air is released into a roof space it may condense and create problems. See Chapter 3. It is best practice to exhaust air directly outdoors from high moisture generation rooms, such as bathrooms, kitchens, and laundries.

- Ventilation of drier outdoor air into a building cavity can assist with drying any moisture present.

When moisture forms in a building or within a cavity it is usually only problematic if it is persistent or continual. Ventilation of air will significantly reduce this likelihood. For most of Australia (other than for climate zone 1) the moisture generated within buildings often results in higher indoor moisture (higher dew point / higher vapour pressure) levels. It is therefore useful for slight ventilation of drier outdoor air into the building and building cavities to help moisture to dry – see Note 2 following.

For this approach to be useful

- The dew point of the external air must be lower than the air within the roof space or cavity.
- The rate of removal of moisture from the roof assembly or cavity must be sufficient to allow accumulated moisture to dry in a reasonable timeframe to avoid damage.¹⁵

Note 1. While ventilation of outdoor air can assist with reducing winter condensation and moisture which helps to protect the durability of a building, excessive and uncontrolled ventilation in some environments may detrimentally affect the durability of the building and may downgrade the thermal performance of insulation, particularly for reflective air spaces, changing the temperature profile through the building envelope.

15 Lstiburek J & Carmody J, *Moisture Control Handbook: Principles and Practices for Residential and Small Commercial Buildings* (1994)

Note 2. Consideration should be given to the impact of any ventilation measures on energy consumption for heating and cooling. This may be as a direct result of additional outdoor air requiring heating and/or cooling or reduced thermal resistance of the building fabric.

5.2.4 Thermal bridging

Thermal bridging is a term given to heat leakage through a conductive path that generally bridges insulation. Both metal and timber framed construction is affected by conductive bridging by the framing members and convective thermal bridging at gaps between the framing and any added bulk insulation. Metal framed construction is more prone to conductive bridging than timber framed construction.

The extent of convective bridging depends upon the ability to ensure that air gaps are not created through insulation. This can occur at edge gaps between framing and bulk insulation and avoidance requires quality installation. It is also sometimes unavoidable for down lights in ceilings for electrical safety. According to ASHRAE Fundamentals Handbook, a 4% void area in wall insulation with an R-Value of 2 m².K/W increases heat loss by 15% and a 4% void in ceiling insulation with an R-Value of 3.3 m².K/W causes a 50% increase in heat loss, see Figure 5.2. ¹⁶

The extent of conductive bridging depends upon the insulation details. For a framed element, such as a wall, if the framing does not bridge the insulation, as with insulation board attached to the external flange, then no bridging occurs. With bulk insulation placed between framing members in conventional clad construction, thermal bridging does occur, see Figure 5.2 (a). The framing members are more conductive than the insulation providing a thermal bridge through the insulation, see Figure 5.3.

Thermal bridging leads to two main problems; see Figure 5.2 (a):

- A downgrade in the thermal resistance of the wall.
- Potential moisture problems on the frame and internal lining.
 - The framing becomes cooler than the surrounds making it prone to condensation
 - The internal lining adjacent to the frame can become much cooler than the lining adjacent to the insulation. Depending upon the air temperature and humidity, these cooler areas can form condensation and possible mould growth. Dust settling on the moisture may lead to patterned staining of the lining, see Figure 5.3 and Chapter 3.

16 ASHRAE Handbook Fundamentals SI Edition, American Society of Heating, Refrigeration and Air-Conditioning Engineers, Atlanta, 1993, p21.4.

Addressing the thermal bridge at the frame, using insulating board, insulating strips, battening out the cladding, or using cladding that has inherent insulation, such as polystyrene cladding, can be used to reduce the impact of a thermal break. Placing the thermal break on the cold side of the framing (outside face for cold climates) will keep the frame warmer and less prone to condensation than if the thermal break was placed on warm side of the frame, see Figure 5.2 (b).¹⁷

The higher the resistance offered by the thermal break the lower the downgrade in thermal performance and the lower the risk of potential moisture problems on the frame and internal lining.

ABCB commissioned studies into the impact of thermal bridging upon building thermal performance, *Effects of Thermal Bridging on Heat Losses of Roofs in Australian Houses* and *Effects of Thermal Bridging on Heat Losses of Walls in Australian Housing*. From these studies specific BCA thermal break requirements were developed for:

- external cladding of weatherboards, fibre cement sheeting or similar light weight (low R-Value) material attached directly to the metal frame; and
- metal roofs with exposed rafters attached to metal purlins or battens and a ceiling directly beneath the metal purlins or battens.

Figure 5.2 Thermal breaks improve clad wall performance.

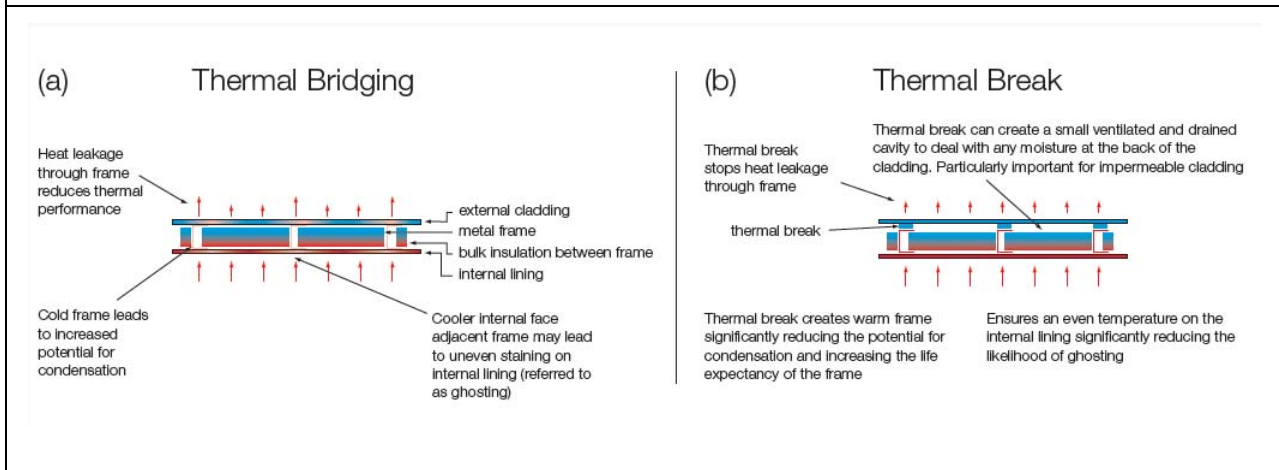

¹⁷ National Association of Steel House Framing, *Thermal Bridging*, NASH News, March/April 2006.

Figure 5.3 – Bridging of framing members combined with high indoor humidity can lead to patterned staining of plasterboard

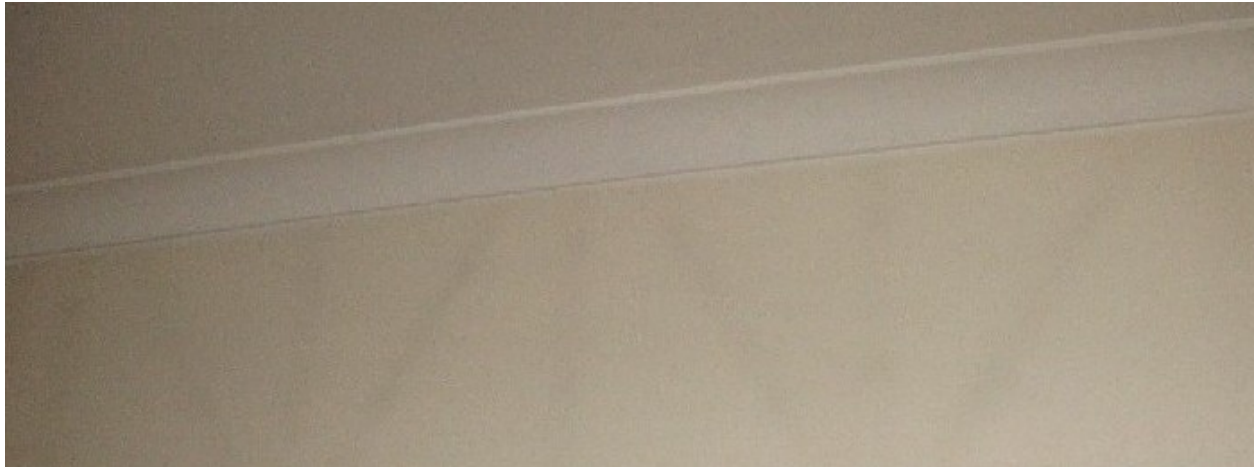

5.2.5 Reverse Vapour Drive

The phenomenon of reverse vapour drive can lead to a risk of condensation in the summer.

If the building envelope includes materials that store quantities of moisture, such as timber cladding, plywood sheathing or brick, sunlight can drive water vapour towards the interior, potentially reaching dew point on impermeable interior linings. Factors that contribute to this risk are:

- where the building envelope does not have the capacity to dry
- where materials that form part of the exterior cladding or roof deck can store moisture
- where the interior is conditioned to un-typically low temperatures
- where vapour barriers are located on the interior face of the insulation or where interior linings are vapour impermeable

Figure 5.4

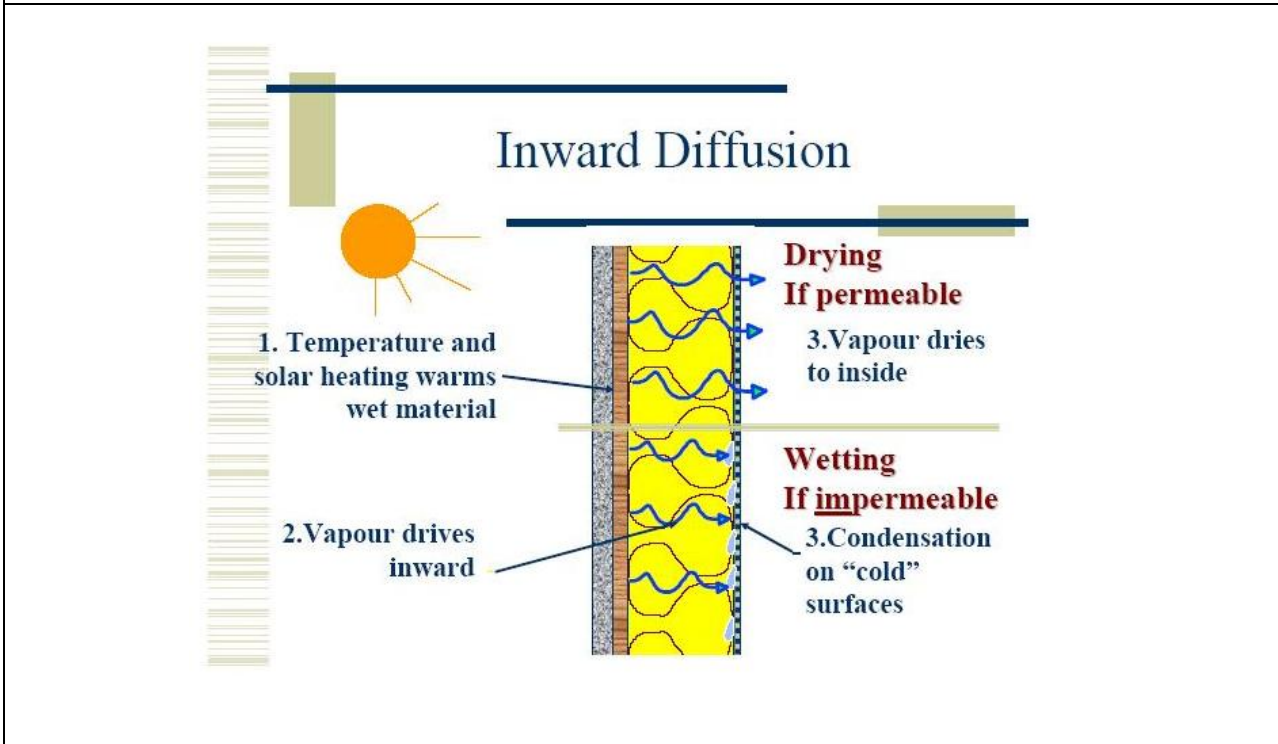

(Source: John Straube University of Waterloo presentation)

5.3 Building Fabric

5.3.1 Roofs

The roof is the most exposed element of the building fabric. Overnight its temperature often drops below the outdoor air temperature as it loses heat via radiation to the cold night sky. The cold roof combined with the vast amount of moisture we generate at times within our homes makes condensation within roofs likely. While it is good practice to minimise the risk of condensation, significant problems will usually only eventuate if condensation is persistent or becomes trapped. The risk of persistent condensation in roofs is greatest in the coolest climate zones (climate zones 7 and 8) although persistent condensation can also eventuate in all climate zones when high internal moisture levels are not controlled.

In warm humid climates internal ceilings should be vapour permeable.

For cold climates, the ceiling plane is the first line of defence against condensation within the roof space. The ceiling can act as an air barrier and can incorporate a warm side vapour barrier against internal moisture moving into the roof space. Whilst this represents best practice, it is often difficult to achieve due to the number of penetrations through the ceiling plane, such that it is desirable that the roof also be capable of dealing with water vapour entering the roof space.

This can be achieved through appropriate use of insulation, membranes and ventilation, and good control of indoor moisture.

Flat pitched and skillion roofs are more prone to moisture (from condensation risk and ingress of water) than pitched roofs with flat ceilings or roofs with large air spaces beneath because it is more difficult to provide sufficient ventilation and to allow for drainage of any moisture without ponding. Therefore more care should be taken with such roof constructions.

The occurrence of condensation in metal roofs and tiled roofs varies because of the very different nature of these roofing materials, the options available for ventilation, and the different approaches to the location of insulation and sarking. The following section has therefore been divided into metal roofs and tiled roofs.

Note: Roofs designed to meet the bushfire requirements of AS 3959 Building in Bushfire Prone Areas require special consideration, refer to Appendix A.

- **Metal Roofs**

Reducing the risk of condensation in cold and temperate climates within metal roofs varies from the situation where no insulation is installed at roof level, to the lower risk situation whereby all of the insulation is installed at the roof level combined with appropriate use of membranes to control moisture. Where a pitched roof has a flat ceiling, the BCA DTS provisions require 50% minimum insulation on the ceiling, which is also preferable from an energy efficiency view point. Note: this is not limited to metal roofs.

- **No insulation or pliable membrane at the roof level**

The risk of condensation forming upon the internal surface of a metal roof is highest where no appropriate insulation is installed at the roof level, however such roofs also have greater natural drying potential.

A metal roof without insulation at the roof level relies upon regular drying and the control of indoor moisture to reduce condensation risk.

- Passive ventilation of outdoor air, combined with the rapid increase in temperature that occurs within the roof space during the day provides regular drying opportunities for condensation that forms overnight. Pitched roofs with flat ceilings typically provide ventilation through edges of roof sheet profiles and at ridges. Achieving suitable ventilation for flat metal roofs and metal skillion roofs is more difficult

- For flat roofs, warm air naturally rises but has little tendency to move laterally, except when a strong wind blows into roof vents or causes substantial differences in air pressure on opposite side of the building. Consequently, ventilation of the roof space will not prevent condensation on the underside of the cold roofing¹⁸.
 - Skillion roofs, typically do not have a large air-void to accommodate high levels of water vapour or to allow for drying by natural ventilation.
- Levels of water vapour entering the roof space should be minimised. This could involve strategies such as regular ventilation of rooms and ensuring that moisture generated within the home is exhausted directly outdoors.
 - Where indoor moisture levels are likely to be high, quality airtight construction or the provision of a vapour barrier at the ceiling should limit the entry of indoor water vapour to the roof cavity by also acting as an air barrier.

Although metal roofs without insulation at the roof level have been commonly used throughout Australia, increased airtightness and the increasing levels of ceiling insulation needed to meet BCA requirements result in both hotter and colder temperatures within the roof, thereby increasing the importance of strategies to reduce risk and avoid problem condensation. This detail of no insulation at the roof level is not recommended in climates with cold winters (BCA climate zones 4, 7 and 8). In climate zone 1, this detail may also result in intermittent condensation as a result of night sky cooling of the roof combined with often-high humidity levels.

- **Sarking installed at roof level**

When a sarking is installed beneath a metal roof the risk of condensation is reduced relative to the situation where no insulation is installed at the roof level. However the amount of natural ventilation that aids drying is also reduced.

Reflective Foil Insulation

Typical Australian practice has relied upon the use of draped unperforated reflective foil insulation, which also acts as a vapour barrier. The foil stops vapour within the roof space from contacting and condensing upon a metal roof.

¹⁸ AS1562.1- 1992 Appendix A

In higher risk locations and building types, measures should also be taken to tape overlaps and seal up penetrations to ensure the integrity of the vapour barrier. Because the foil is slightly warmer than the metal roof, less condensation will form on the underside of the foil than would form on the underside of a metal roof without foil. The reflective foil is draped beneath the roof to achieve a reflective air space.

Vapour Permeable (breathable) Membrane

An alternative approach, which is more commonly used in cold and temperate climates overseas including New Zealand, relies upon a pliable membrane that is vapour permeable and absorbent or highly vapour permeable and non-absorbent. The membrane is positioned to allow an air gap under the roof sheet so that water vapour within the roof space is able to permeate through the membrane and condense upon the roof. If significant condensation forms it is either temporarily stored by an absorbent membrane until daytime drying conditions prevail or it will drain to the gutter. For drainage to be effective there must be a clear path for condensate to ensure that moisture is not trapped by fixings or purlins. With this detail the materials contained between the sarking and roof should be able to accommodate the wetting and drying cycle, which will be more regular in colder climates.

Typical practice for installing sarking beneath metal roofs has the sarking draped between the metal sheet and supporting roof batten and as such will not allow a clear passage for drainage of condensation. An alternative installation method is required when using vapour permeable (breathable) membrane beneath a metal roof to ensure clear drainage and advice must be sought from manufacturer.

When vapour permeable or impermeable pliable membranes are installed beneath a metal roof, condensation risk is also reduced by ventilation of outdoor air into the roof space, and by reducing the amount of water vapour entering the roofspace. Appropriate ventilation is required to allow drying of a roofspace. High volume, high speed ventilation of the roof space may undermine the performance of insulation, particularly reflective foil insulation, and may introduce unwanted air particulates, such as corrosive elements in marine and or industrial environments.

- *Insulation directly beneath a metal roof*

Foil faced fibre insulation blankets

A common practice for metal roofs has been to install insulation blanket and reflective foil directly beneath the roof. The foil acts as a vapour barrier, stopping water vapour within the roof space from reaching and condensing on the underside of the metal roof and wetting the insulation. Particularly in high risk locations and building types, measures should also be taken to tape overlaps and seal up penetrations to ensure the integrity of the vapour barrier.

This practice reduces the risk of condensation on the underside of the foil to a greater degree than the approach of having only a draped reflective foil beneath a metal roof.

Localised condensation risk can be further minimised by preventing the insulation blanket from being compressed by supporting purlins / battens to reduce thermal bridging which may bring the structure below dew point at times, see Section 5.2.4.

The foil surface is thermally isolated from both the cold roof and the warmer indoor conditions. The foil temperature is predominantly dependent upon the amount of insulation at the roof level relative to the amount of insulation on the ceiling. The more insulation installed at the roof level the closer the temperature of the foil on the underside of the insulation blanket is to the interior temperature thus reducing the risk of condensation. Likewise, the more insulation installed at the ceiling level the closer the temperature of the foil on the underside of the insulation blanket is to the exterior temperature thus increasing condensation risk. Appropriate ventilation of outdoor air into the roof cavity is advisable to ensure that any moisture that enters the roof cavity may dry. Control of indoor moisture will also reduce condensation risk. Ventilation that introduces air at outside temperature in high volumes, or at high air flow speeds may undermine the performance of insulation, particularly reflective foil insulation, and may introduce unwanted air particulates, such as corrosive elements in marine and or industrial environments.

Note: Whilst insulation blankets and reflective foil is usually installed with the reflective foil facing downward, in tropical climates (BCA climate zone 1), it is recommended to install the reflective foil placed upward as moisture flow is typically inward, particularly for air-conditioned buildings, see Figures 5.5 & 5.6. Inclusion of an additional layer of unperforated foil beneath the blanket will further protect the blanket from moisture below and add to the roof summer insulation R-Value.

Figure 5.5 Insulation configuration for (a) temperate and (b) tropical scenarios.

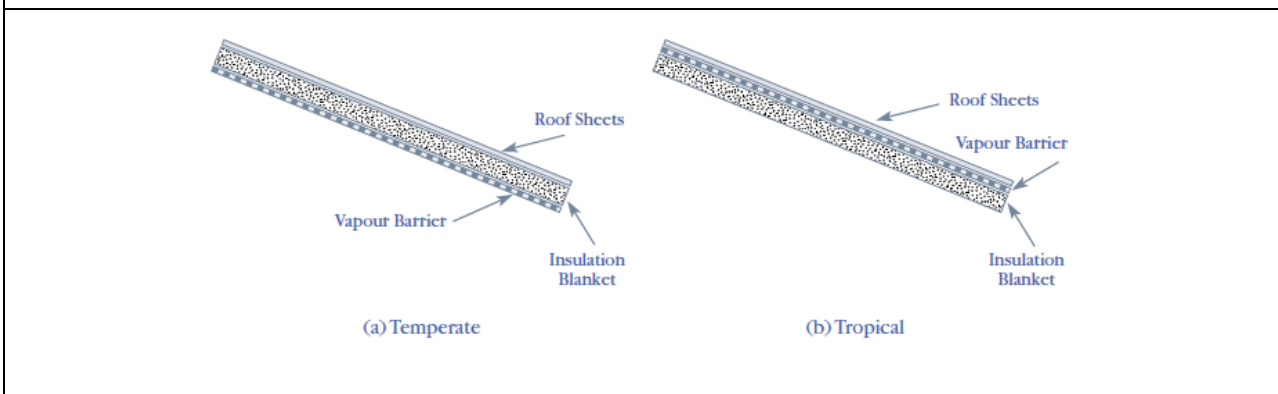

Source: BlueScope Steel, Condensation and Insulation, CTB 11, May 2007.

Figure 5.6 Photo showing moisture penetration due to the absence of a vapour barrier in a tropical environment



Rigid, non-porous insulation boards and panels

Other methods of insulating at the roof level are often used particularly where high insulation values are required, in buildings with an inherently high internal vapour pressure such as swimming pools and museums, or where space limitations restrict the use of fibrous insulation blankets. If a non-porous rigid insulation board or composite insulation panel is installed across the roof structure this can keep the entire roof above dew point. If combining this with fibrous insulation, the same principals as above apply to ensure the balance of the insulation types is such that it keeps the underside of the board above dew point.

- **Tiled roofing**

Tiled roofing typically has insulation installed upon or near the ceiling lining and may or may not include sarking. Under the Deemed-to-Satisfy provisions of the BCA, sarking is mandatory for tiled roofing in certain locations and roof slopes, to deal with the ingress of wind driven rain or in bushfire zones to improve resistance against ember attack.

- ***Tiled roofs without sarking***

A tiled roof without sarking has the potential for condensation to form on the lower surface of tiles from time to time. As most tiles are absorbent they have the ability to absorb and store the condensate so that once drying conditions prevail, the natural ventilation around each tile facilitates drying.

The condensation risk in tiled roofs without sarking will also be reduced through control of indoor moisture and roof space ventilation.

- Indoor moisture should be minimised. This could involve strategies such as regular ventilation of rooms and ensuring that moisture generated within the home is exhausted directly outdoors.
- The ceiling should limit the entry of indoor water vapour to the roof cavity by acting as an air barrier through quality airtight construction or by provision of a vapour barrier where indoor moisture levels are likely to be high.

- ***Tiled roofs with sarking***

Draped sarking is commonly used under a tiled roof. Typical Australian practice has been to use reflective foil to create a reflective roof space to improve thermal efficiency. Since almost all reflective foils also function as a vapour barrier this can have unintended consequences. Primarily the sarking acts to drain external moisture and to be effective, installation must provide clear drainage to gutters and avoid ponding in accordance with AS4200.2. The draped sarking provides a slightly warmer surface than the underside of the roof tiles thereby reducing the amount of condensation that would otherwise have formed on the underside of the roofing. However the ability to absorb and re-release the moisture is less as the foil surface is non-absorbent and the amount of natural ventilation that aids drying is also reduced. For this reason if a vapour impermeable sarking is used under roof tiles, such as a reflective foil insulation, in cold and temperate climates the roof space should be adequately ventilated at the ridge and eaves in a way that ensures no dead air spaces. Pliable membranes used as sarking below tile roofs in Australia are limited by duty classification as set out in Table 2 of AS/NZS 4200.1.

An alternative approach, which is more commonly used overseas, is the use of sarking that is both vapour permeable and absorbent, highly vapour permeable, or in some cases also air permeable. Water vapour within the roof space is able to permeate through the membrane and through the air gaps in the roof tiles. If significant condensation forms on the underside of non-porous tiles, it will drain to the gutter when installed per AS4200.2.

The inclusion of sarking under a tiled roof significantly reduces the natural ventilation of the roofspace. Therefore appropriate ventilation of outdoor air into the roof cavity is advisable to ensure that any moisture in the roof cavity may dry. In addition control of indoor moisture levels will reduce condensation risk. Where a sarking that is vapour permeable is used, the requirement to ventilate the roof space is dependent on the degree of vapour and air permeability of the sarking.

- **Flat Roofs, balconies and roof terraces**

- **Cold and temperate climates**

Flat concrete and metal deck roofs with waterproofing membranes are particularly prone to condensation problems because it is difficult, (i) to ensure the integrity of a vapour barrier, (ii) to ensure adequate ventilation beneath the structural deck or slab, and (iii) to provide scope for drainage or drying of condensate to the exterior.

The two options are to have a warm roof where insulation above the structure keeps the structure above dew point or a cold roof where insulation is placed below the structure and other measures need to be taken.

- **Warm (Upside-Down) Roof**

This approach also referred to as a PMR (Protected Membrane Roof) or IRMA (Insulated or Inverted Roof Membrane Assembly) insulates above the waterproofing membrane maintaining the entire roof structure within the insulation envelope and thus above dew point. The insulation is restrained from wind uplift by a layer of ballast, paving or a complete green roof system. As this insulation is located where it could be exposed to moisture, it must be closed cell, impermeable and of high compressive strength.

If, because of height or other restrictions, it is impossible to have all the insulation above the slab, additional insulation can also be used below the structure provided that there is sufficient insulation above to keep the slab or deck above dew point. Although tempting to add more insulation below the structure, as a rule of thumb, two-thirds of the insulation should be above the structure to avoid bringing the dew point back inside the structure. When splitting the location of insulation above and below a vapour barrier, particularly where porous insulation is being used, it is highly recommend that a condensation risk analysis is carried out, refer Chapter 4.

- **Cold Roof**

Insulation located beneath the structure means that the structure is maintained at the outside temperature. Unlike the warm roof approach, because the structure will fall below dew point, preventative measures are required to avoid condensation.

To reduce the amount of vapour reaching the slab or deck, a vapour impermeable insulation board can be used, or a continuous vapour barrier should be installed on the warm underside of porous insulation. In addition, adequate ventilation should be provided between the insulation and the slab or deck.

In mixed climates where there is potential for reverse vapour drive, a smart vapour retarder is preferable to a vapour barrier. This works in some conditions as a vapour barrier but in other conditions as vapour permeable which provides drying potential towards the interior.

5.3.2 Walls

The key design principle for walls is to limit or stop moisture getting into a wall and allow any moisture that does get in to get out. Trapped moisture within walls is responsible for most significant moisture related building issues. Moisture can evolve from various sources including ground moisture, construction moisture, the weather and internal moisture. These moisture sources can cause issues related to both surface condensation and interstitial condensation.

Condensation on internal surfaces is reduced through inclusion of insulation within the wall. The main potential for high levels of surface condensation is where thermal bridging is not adequately dealt with. This may be as a result of inappropriate detailing, poor installation of insulation, see Chapter 5.2.4, or where window frames or doors are thermally linked to the external layer of the wall.

Interstitial condensation can be reduced by controlling vapour flow through the wall by considering the vapour resistance of the materials that make up the wall. The requirements to achieve control of vapour flow through a wall are dependent upon the predominant direction of vapour flow. This is typically influenced by climate.

- In cold climates, vapour flow is typically outward, so place materials with high vapour resistance near the warm inside lining and low vapour resistance materials near the cold outside lining.
 - A vapour barrier should only be installed on the warm side of the insulation
 - If sarking is installed it should be of sufficiently low vapour resistance (i.e. be sufficiently vapour permeable.) Absorbent sarking may be beneficial for non-absorbent cladding, to temporarily store any moisture and release it when drying conditions prevail
 - If the external wall cladding is impermeable then any accumulation of condensation will be limited if ventilation and or drainage can occur immediately behind the cladding
- In warm humid climates, vapour flow is typically inward, so place materials with low vapour resistance near the inside lining and greater vapour resistance materials near the outside lining
 - If sarking is installed and the building is air-conditioned then it should also be a vapour barrier. If the wall cladding is also of high vapour resistance or impermeable then it should allow slight ventilation and or drainage immediately behind the cladding to avoid moisture becoming trapped
 - Avoid internal linings and paints that have high vapour resistance
- In other climates, the direction of vapour flow varies, so it is best practice that all materials used within the wall are vapour permeable or breathable
 - If sarking is installed it should be sufficiently vapour permeable

- If the external wall cladding is impermeable then it is good practice to aid drying with slight ventilation and or drainage immediately behind the cladding. Where there is no such provision, absorbent sarking may be beneficial to temporarily store any condensation and release it when drying conditions prevail

Interstitial condensation can also be reduced by limiting air movement through the wall. Sarking should be installed to limit outdoor air into the wall and internal (plasterboard) linings should be installed to be as airtight as possible to limit indoor air into the wall.

Controlling indoor moisture levels will further reduce both surface and interstitial condensation risk. Reducing the levels of internal moisture through regular ventilation of rooms and ensure that the moisture from activities within the home that generate vast amounts of moisture is exhausted directly outdoors.

Figure 5.7 illustrates good practice for winter moisture control for walls for Australian climates other than tropical.

Figure 5.7 Good practice for moisture control for walls for Australian climates other than tropical

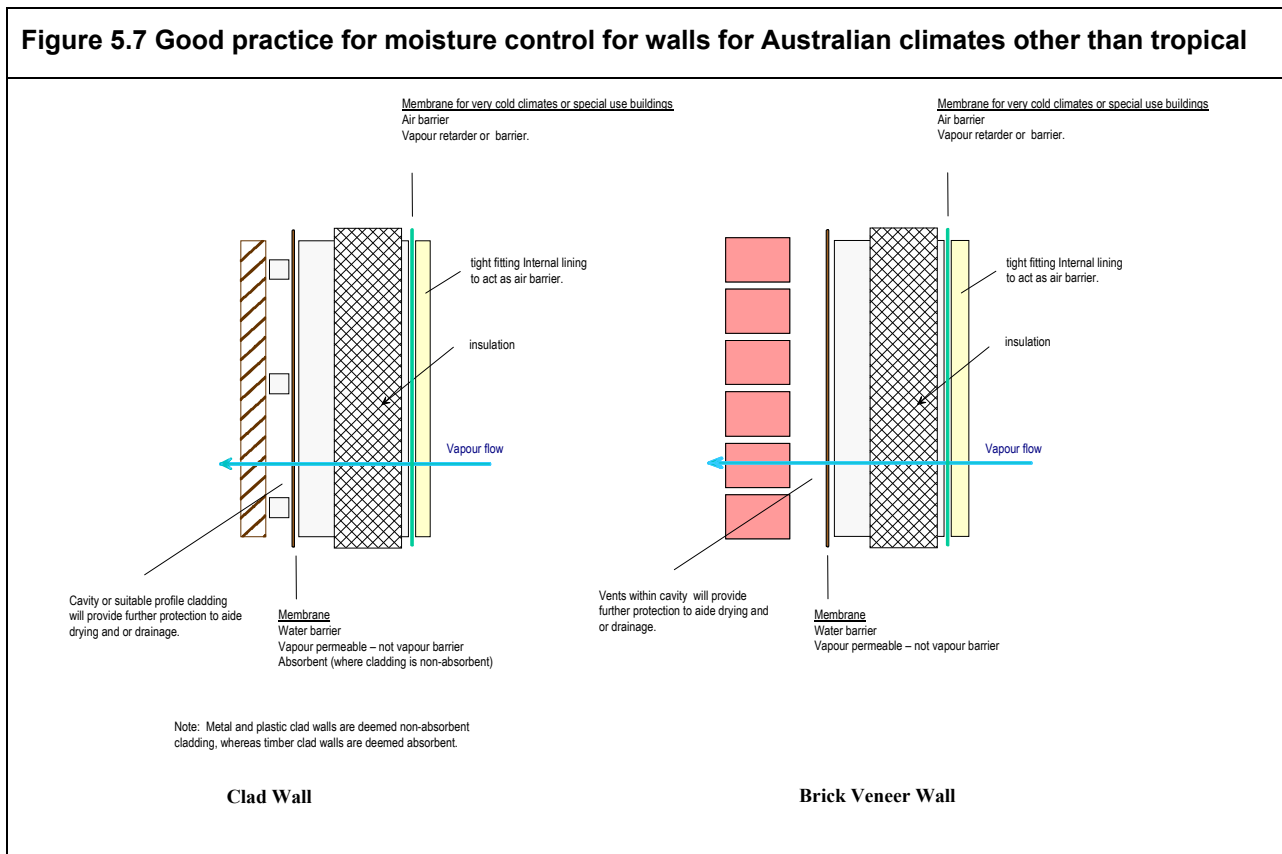

5.3.3 Floors

Ground moisture must be dealt with in order to prevent potential condensation in both the floor and the remainder of the building. Moisture evolving from the ground can often be the cause of high indoor humidity causing surface and or interstitial condensation within walls and roof spaces.

A damp proof membrane must be installed under slab-on-ground construction in accordance with the BCA, which protects the building above from moisture. Unheated slab-on-ground floors track the ground temperature. Under some conditions this can lead to intermittent surface condensation on slab floors, an example is provided as a Case Study in Appendix A.

Suspended floors must be protected from moisture beneath and from trapping water or interstitial condensation

- Adequate sub-floor ventilation should be provided to reduce moisture levels beneath the floor. Where the water table is high and or the ground is particularly damp, a damp proof course over the soil beneath may be suitable to protect the building above
- Where vapour permeable insulation material is used beneath the floor in cold and temperate climates, any membrane supporting the insulation should be sufficiently vapour permeable to ensure that water or interstitial condensation may escape
- The use of vapour impermeable insulation such as extruded polystyrene under the floor can be an effective air and vapour resistant layer reducing interstitial condensation risk especially when installed continuously.

The BCA contains measures for acceptable construction practice to control ground moisture, including drainage, use of vapour barriers to protect from moisture below, and sub-floor ventilation to aid drying, see Figure 5.8 and 5.9. Poor detailing or holes in vapour barriers may cause elevated moisture within a home leading to condensation issues.

Figure 5.8 Examples of BCA Acceptable Construction Practice to Control Ground Moisture

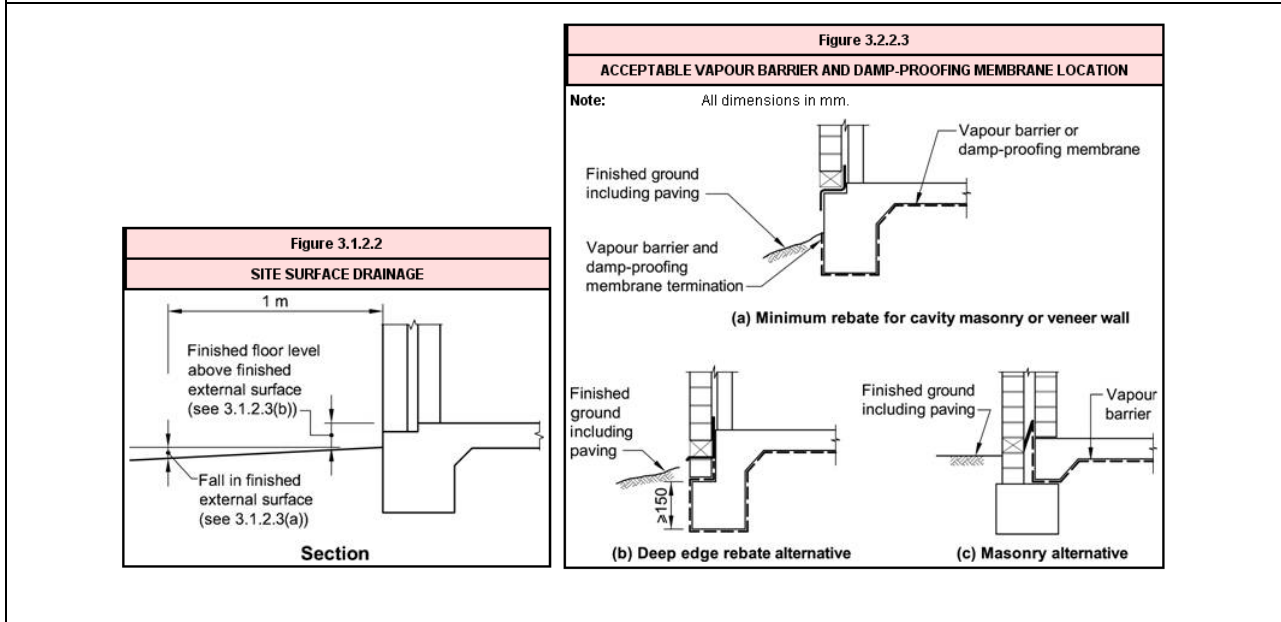
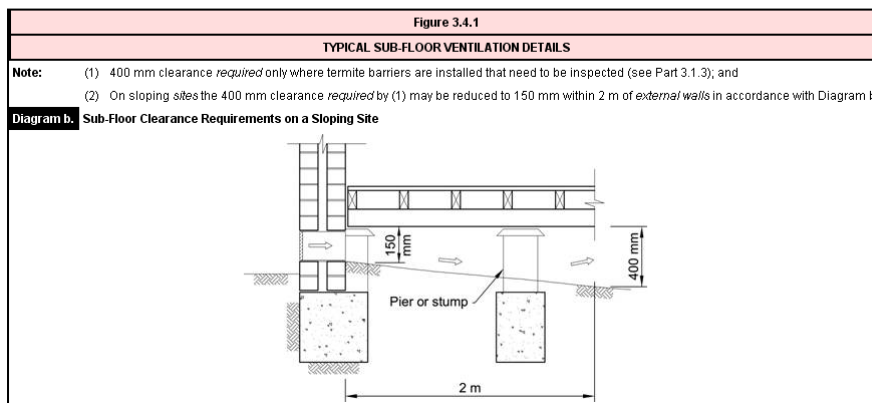
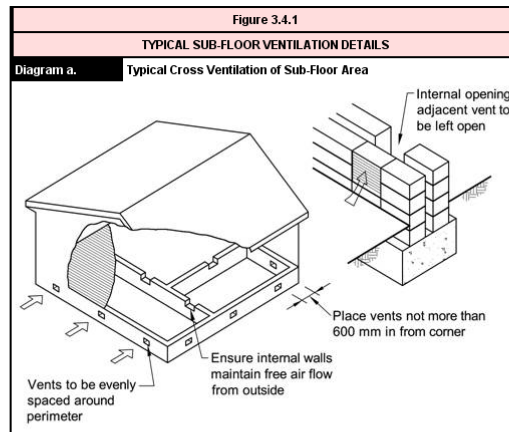

Figure 5.9 Examples of BCA Acceptable Construction Practice to Control Ground Moisture



Chapter 6 Existing Regulations and Standards

6.1 Overview

The following information from the BCA and Australian Standards has been provided to give the designer, architect or building professional a starting point for navigating through the relevant legislation and standards which apply to managing the risk of condensation and damp in buildings. The information is not intended to be exhaustive and does not override or replace the requirements of the BCA or other legislation. This information is current at the time of publishing but readers should refer to the BCA for the latest information.

Building control is the responsibility of each State and Territory. The BCA, which forms Volume One and Two of the NCC, is adopted via the State and Territory building legislation as the technical standard for the design and construction of buildings. The legislation generally applies the NCC to new buildings, new building work in existing buildings and changes in building classification or use. The information below is of a general nature and refers to the BCA provisions without any State and Territory variations. The specific arrangements and requirements in the relevant State or Territory jurisdiction may be different to that described.

6.2 National Construction Code

The structure of the NCC is comprised of Objectives, Functional Statements, Performance Requirements and Building Solutions. The Objectives and Functional Statements are provided for guidance only. For a Building Solution to comply with the NCC it must meet the Performance Requirements. Compliance with the Deemed-to-Satisfy (DtS) Provisions is one way to satisfy the Performance Requirements. Australian Standards are not mandatory unless they are referred to in legislation; this includes reference in the NCC.

The NCC requirements for Damp and Weatherproofing are in Part F1 for NCC Volume One (Class 2 to Class 9 buildings) and Part 2.2 for NCC Volume Two (Class 1 and Class 10 buildings – housing provisions). The Objectives of the two parts are similar, except that Part 2.2 also covers the discharge of swimming pool waste water.

Part F1 Damp and Waterproofing

The Objective of this Part is to:

- (a) safeguard occupants from illness or injury and protect the building from damage caused by:
 - (i) surface water; and
 - (ii) external moisture entering in a building; and
 - (iii) the accumulation of internal moisture in a building; and
- (b) protect other property from damage caused by redirected surface water.

The Functional Statements relevant to damp and condensation in Volume One are FF1.2 and FF1.3. Functional Statement F2.2.2 in Volume Two is the same as FF1.2 in Volume One.

Functional Statement FF1.2

A building is to be constructed to provide resistance to moisture penetrating from the outside including rising from the ground.

Functional Statement FF1.3

A building is to be constructed to avoid the likelihood of–

- (a) the creation of unhealthy or dangerous conditions; and
- (b) damage to buildings elements, caused by dampness or water overflow from bathrooms, laundries and the like.

The Performance Requirements corresponding to these Functional Statements are FP1.4 and FP1.5 in Volume One, and P2.2.2 and P2.2.3 in Volume Two.

FP1.4

A roof and external wall (including openings around windows and doors) must prevent the penetration of water that could cause—

- (a) unhealthy or dangerous conditions, or loss of amenity for occupants; and
- (b) undue dampness or deterioration of building elements.

FP1.5

Moisture from the ground must be prevented from causing—

- (a) undue dampness or deterioration of building elements; and
- (b) unhealthy or dangerous conditions, or loss of amenity for occupants.

As stated in F1.0, the Volume One DtS Provisions that demonstrate compliance with Performance Requirement FP1.5 are F1.1 to F1.13; there are no DtS Provisions for FP1.4.

The DtS Provisions in Volume Two that demonstrate compliance with Performance Requirements P2.2.2 and P2.2.3 include:

- Part 3.2 Footings and Slabs;
- Part 3.3.4 Weatherproofing of Masonry;
- Part 3.4.1 Sub-floor Ventilation;
- Part 3.5.1 Roof Cladding;
- Part 3.5.3 Wall Cladding; and
- Part 3.6 Glazing.

In assessing compliance with the damp and weatherproofing provisions, consideration should be given to the implications of the energy efficiency provisions in Section J in Volume One, and Part 2.6 and Part 3.12 in Volume Two. Changes to the energy efficiency provisions in BCA 2010 that affect the condensation risk in buildings include generally higher insulation levels, including higher minimum R-values for opaque building elements and increased glazing stringency.

The impact of the energy efficiency provisions on the condensation risk within a building needs careful attention from those involved in the design and construction of buildings, including architects, builders and services engineers.

For more information about the BCA energy efficiency measures, please refer to the ABCB website at <http://www.abcb.gov.au>.

6.3 Australian and International Standards

The following list of Australian and International Standards is a reference to current information which may assist in the correct selection and specification of insulation, vapour barriers and roof and wall cladding systems. This list is not considered exhaustive.

6.3.1 AS 1562.1-1992 Design and installation of sheet roof and wall cladding Part 1: Metal

This Standard sets out requirements for the design and installation of self-supporting metal roof and wall cladding, subjected to out-of-plane loading.

Under Section 3 Design, Section 3.3 Water Penetration, the cladding system shall provide adequate water resistance when subjected to a 100 year storm (see AS2180). In addition to AS2180 consideration should be given by building professionals to allowing internal vapour to escape a building's fabric.

Under Section 4 Installation 4.1 General, the cladding system shall be installed in accordance with the design specifications or the manufacturer's installation specification, as appropriate. Design professionals need to ensure manufacturers' specifications are suitable for their specific project, location, and building requirements.

This standard has an Appendix A entitled 'Roof Ventilation, Water Vapour and Condensation. This section is informative and highlights that condensation is one of the biggest single items contributing to the deterioration of buildings. It can occur in all types of buildings and is largely due to poor design or inappropriate use of materials.

6.3.2 AS/NZS 3999-1992 Thermal insulation of dwellings -Bulk – Installation requirements

This Standard deals with the installation of bulk thermal insulation in all classes of dwellings. Section 2 on Pre-installation Considerations and Inspection has a Section 2.5 entitled Condensation Assessment, providing the following advice. Consideration should be given to the need to include vapour retarders, ventilation or additional ventilation to reduce the potential for condensation (see Clause 3.2(h) and notes to Clause 4.3.1 (c)). Clause 3.2 (h) as follows, Vapour retarders, where specified in conjunction with bulk insulation, shall be installed on the side which is warmer during the season when conditions conducive to condensation exist. The following notes also appear in the Standard:

Notes:

- Thermal insulation will reduce the risk of condensation on inside surfaces in cold winter climates and on outside surfaces in hot humid climates where buildings are air-conditioned. A vapour retarder may be required on the warm side to prevent the passage of water vapour through the insulation to colder regions where it may condense.

- In some cases the correct location of a vapour retarder is not clear and it may be necessary to be guided by local practice.
- For a fuller discussion of the control of condensation in buildings, reference may be made to BS 5250.

British Standard BS 5250:2002 is the British Code of Practice for Control of Condensation in Buildings. It should be noted that this standard applies to cold and cool temperate climates and this and other British or European standards do not address the wide range of climates in Australia. ASHRAE standard 160-2009 Criteria for Moisture Control, Design and Analysis in Buildings addresses a much broader range of climates, including tropical climates. There are also building code requirements for vapour retarders proposed by ASHRAE¹⁹. However the more populated areas of Australia are much warmer and drier than the more populated areas of continental USA. Special provisions need to be made for air-conditioned buildings in tropical climates in Australia.

6.3.3 AS/NZS 4200.1-1994 Pliable building membranes and underlays-Part 1: Material

This Standard sets out the requirements for materials suitable for use as a pliable building membrane (also known as underlay) in any of the following circumstances:

- When it is intended to act as a sarking membrane or thermal insulation or a vapour barrier when installed in a building structure.
- When installed either independently, or as a facing to other materials such as insulation materials.
- When installed in, domestic, commercial or industrial buildings.

This Standard is intended for use by manufacturers to assist in producing adequate building membrane materials, and by the end user wishing to specify the correct grade of pliable building membrane material for their specific purposes.

This standard is important from a moisture management perspective as it defines and provides a classification system for water barriers, vapour barriers and absorbency of pliable building membranes. The standard does not however provide a classification system for vapour permeable (breathable) membranes.

This Standard sets only the minimum requirements for the installation of pliable building membranes and does not purport to provide for all the requirements for any particular installation.

19 Lstiburek, J. (2004) Understanding vapour Barriers, ASHRAE Journal, August, pp. 40-50.

This Standard contains an Appendix A - Protection Against Condensation which is informative only. The Appendix highlights that condensation is a very complex problem and can occur under a variety of conditions, not just cold conditions. The Appendix provides advice about the need to place the pliable building membrane/material in the correct location based on the environment and its intended use. The appendix suggests consulting additional literature available from the CSIRO/BRANZ/ASHRAE when building in areas where condensation is likely to occur. Clause A2 of this Appendix notes that where condensation is likely to occur, the appropriate use of a pliable building membrane as a vapour barrier or as thermal insulation, or both, can be effective as a preventative measure.

6.3.4 AS/NZS 4859.1:2002 Materials for the thermal insulation of buildings Part 1: General criteria and technical provisions

This Standard specifies requirements and methods of test for materials that are added to, or incorporated in, opaque envelopes of buildings and building services, including ductwork and pipe work, to provide thermal insulation by moderating the flow of heat through these envelopes and building services.

Specific requirements for individual materials or insulation types are given in Sections 5 to 9 of this Standard.

According to the Standard it is applicable to the full range of climatic and environmental conditions that exist under normal circumstances. It is intended for use by regulatory and specifying authorities, insulation manufacturers, developers, architects, builders and building engineers, property managers and commercial and residential building owners. For guidance on installation see AS3999 and AS/NZS 4200.2.

Appendix A Case Studies

The case studies presented in this Appendix provide examples of homes within Australia that have suffered significant condensation problems. Significant condensation problems are often a result of a series of compounding factors associated with building detail, climate, building use and local site factors.

The remediation measures presented are the solutions that were proposed to each of the individual case studies. These remediation measures are not necessarily the best solution or only solution possible to deal with each of the particular significant condensation problems.

A.1 Example: St Ives, NSW

In 2009 new owners moved into a property in the St Ives suburb of Upper North Shore Sydney. A low pitched raked metal roof on one part of the home was replaced. At the same time the roofing contractor with the aim of improving the thermal performance of the roof, also installed multi-cell foil sarking directly under the roof sheet but above the original glass fibre insulation that was supported by a wire mesh.

Figure A.1



The above photograph was taken after the removal of saturated plasterboard and glass fibre, and shows the incorrect location of a foil vapour barrier on the cold upper side of bulk fibre insulation batts.

Early in the first winter of occupancy after the new roof was installed, the owners noticed staining at several locations on the ceiling and discovered that they could poke their finger through the saturated plasterboard.

Figure A.2



Figure A.3



Inspection of the installation of the new roof sheet confirmed that the source of the moisture was not a leak.

Condensation was identified at two layers within the roof build up; (i) directly under the roof sheet; and (ii) on the underside of multi-cell foil.

Although tape was used at the overlaps, without effective sealing of the multi-cell foil, the vapour was still able to pass through overlaps and penetrations, and condensed on the underside of the cold roof sheet. Since the multi-cell foil was draped in order to create a reflective air space, the condensate was dripping off the underside of the roof sheet ponding and draining back into the insulation blanket causing damage to the ceiling.

The surface temperature of the underside of the foil was within one degree of the outside temperature and the relative humidity of the roof void directly under the multi cell foil was over 95% resulting in condensation also forming on the underside of the multi cell foil.

Figure A.4



The photographs taken from inside show where a sample of the multi-cell foil has been removed by the manufacturer for testing to reveal the amount of condensate on the underside of the roof and the drips of moisture from the saturated glass fibre insulation.

Rectification required removal of the existing roof, the multi-cell foil, the original fibre insulation, the supporting mesh and the damaged plasterboard requiring the reconstruction of the roof system on the existing roof framing. A vapour barrier was installed at ceiling level, overlaps taped and new R3 glass fibre insulation installed between ceiling joists. A highly vapour permeable air permeable and water resistant non-metallic sarking membrane was installed across the top of the existing roof purlins without the potential for ponding and an air gap between the roof sheeting and the vapour permeable membrane.

The problem did not recur in the winter of 2010.

Note: Multi-cell reflective foil sarking is a pliable building membrane made from a thin closed cell insulation material bonded on both sides by a reflective foil laminate (RFL).

SUMMARY Example: St Ives, NSW

Problem: Mould growth, plasterboard ceiling collapse and saturation of glass fibre insulation under a low pitched metal roof.

Location: Upper North Shore, Sydney, NSW – Temperate climate

Cause: Incorrect placement of a reflective vapour barrier on the cold side of bulk fibre insulation. Higher relative humidity levels in the roof space led to condensation on the underside of a multi-cell reflective foil sarking, and ponding of condensation on the sarking that then drained back into the roof void.

Solution: A vapour barrier was installed on the warm underside of new glass fibre insulation and a highly vapour permeable underlay was installed under the roof sheet with the provision of an air space between the underlay and the roof sheet.

A.2 Example: Bundaberg - Queensland

This single storey residential home in Bundaberg, Queensland of slab on ground and brick veneer construction with a pitched metal roof, built in the early 1980s, had no observed condensation issues for over 25 years when un-insulated. Older style homes are often leaky and as a result more resilient to higher moisture levels.

One small section of the roof space was retrofitted with around 80mm of cellulose insulation between the joists and at a later date the entire roof space was insulated with a further 80mm polyester insulation between and above the joists. In the first winter after installation of the insulation the house began to experience severe condensation issues leading to internal relative humidity levels of 80% to 92% being recorded throughout the day during the winter months.

Figure A.5 Insulation in the south east corner of the roof space restricted eaves ventilation



The observed moisture was identified as condensation from the underside of the roof sheet. This first became apparent because condensation dripping at various points onto the plasterboard ceiling led to mould growth on the ceiling and cornices. Although the roofing timber has not reached critical moisture levels, there was evidence that condensation was running down the underside of the roof sheet and being absorbed by the roof battens.

“Higher levels of insulation may introduce unforeseen problems where they are incorporated into construction styles which have previously been relatively immune to condensation. This is because insulation, whilst it keeps some surfaces warm, also keeps other surfaces cold.

A simple example is domestic roof spaces. High levels of ceiling insulation mean that roof spaces are colder as they are not heated to the same extent from below.” (CSIRO, 2001)

The amount of moisture entering the roof space was compounded by the kitchen and bathroom extractor fans ventilating directly into the roof space. The roof space is ventilated with two wind driven roof ventilators. In the main roof section where all the insulation has been placed between the joists, gaps at the eaves from the profile of the roof sheet are still clearly visible.

Figure A.6 Although the roof was ventilated by two wind driven ventilators at the eaves this was insufficient to prevent condensation.



The problem, although not confined to one area of the home, was particularly concentrated in the south east facing bedroom where the condensate has also run down into the timber frame walls. As a result of this room's orientation and occupation pattern it is both the coolest and most humid room of the home overnight. The walls have no insulation, are boarded with plywood and wrapped with an impermeable foil sarking. With no capacity for these walls to drain or dry towards the exterior, critical levels of relative humidity was experienced in the interior throughout the year. In addition the ceiling insulation would have also reduced the ability for the wall cavity to dry via venting to the eaves.

SUMMARY Example: Bundaberg - Queensland

Problem: Roof space condensation under metal roof and other moisture related issues leading to mould growth on ceiling, walls and window frames.

Location: Bundaberg, QLD – Sub-tropical climate

Cause: Adding bulk fibre insulation at the ceiling level of a well ventilated but un-sarked pitched metal roof created cooler roof space conditions and both higher humidity levels and reduced ventilation within the roof space and home. As a result condensation was forming on the underside of the roof sheet which dripped onto the ceiling and also ran down into an un-insulated but fully sarked brick veneer wall. Combined with roof condensate in the walls, higher indoor humidity is likely to have also created interstitial condensation unable to dry out leading to mould growth, particularly in the south east facing bedroom.

Solution: Address inadequate ventilation and reduce condensation at the roof with insulation and vapour barrier or control roof condensate with highly vapour permeable sarking. In this case remedial action was taken to treat the mould and dry out the walls and insulation was removed in some locations to open up ventilation at the eaves. The roof sheeting was replaced and an air and a highly vapour permeable sarking underlay was installed to catch and drain condensate to the exterior.

A.3 Example: Kinglake - Victoria

Having lost their home in the Black Saturday Victorian 2009 bushfires the owner rebuilt the home in brick veneer construction with a 22 degree pitch metal roof and were advised that it was fully compliant with new bushfire requirements.

Within two months of moving into their new house in the winter of 2010 the owners noticed moisture on the exterior face of bricks at the eaves where rain clearly was not the cause. On inspection of the roof space it was likened to a “tropical rain forest” with condensate running down the inside surface of the sarking and dripping off the purlins. The insulation at the ceiling was saturated and the plasterboard ceiling at risk of collapse.

Figure A.7 Condensation on the impermeable foil sarking and purlins



Figure A.8 Mould growth on roof trusses and condensation on the underside of the foil sarking



As the roof space was fully sarked, and all gaps and penetrations were sealed, the roof was unable to “breathe.” Water vapour from inside building accumulated in a short space of time with no provision for ventilation or for drainage of condensate. The owner described the mineral wool at the eaves above the frame as “effectively acting as one big continuous sponge around the perimeter of the building.”

Figure A.9 Removal of the saturated mineral wool and sarking from the eaves revealed that the brick and timber has also absorbed condensate. Mould growth on the roof trusses was significant.



Placing more of the insulation directly under the roof sheet, rather than at the ceiling, with appropriate placement of vapour barriers would have avoided this problem. Guidance within NCC Volume Two is that “reflective insulation or sarking installed on the cold side of the building should be vapour permeable.” The risks of sealing up the building to resolve particular issues such as energy efficiency, weather tightness or bush fire risk can have other impacts if not addressing potential condensation risks.

NOTE: Homes being built to the new requirements in bushfire zones are at particularly risk of condensation problems. The homes are required to be more airtight than conventional construction, particularly for flame zone (refer AS 3959), and a large portion of homes requiring bushfire design are located in cool and humid climates.

SUMMARY Example: Kinglake - Victoria

Problem: Roof space condensation in an unventilated roof space fully sealed with foil sarking and no provision for ventilation.

Location: Kinglake, VIC – Cool temperate climate

Cause: Adding bulk fibre insulation at the ceiling level of an unventilated pitched metal roof with a vapour impermeable foil sarking resulted in high humidity levels in the roof space leading to condensation dripping from purlins, running down the underside of the sarking, collecting in the mineral wool at the eaves, in the ceiling insulation and ponding inside ceiling top hat battens.

Solution: In the interim, the owner has had to remove the saturated insulation from the ceiling, run mechanical ventilation to dry out the entire roof space and replace the mineral wool and sarking at the eaves with a compliant mesh to improve ventilation.

Options to resolve this problem are to improve roof-space ventilation, address the sources of moisture, and the condensation under the roof sheet. With mesh installed at eaves, roof space ventilation can be improved by installing compliant ridge ventilation. Sources of moisture into the roof space can be addressed by venting of kitchens and bathrooms directly to the exterior and improving the air and vapour tightness of the ceiling.

Condensation at the roof can be reduced by replacing the impermeable foil with insulation and a vapour barrier beneath or controlled with a highly vapour permeable sarking underlay installed to catch and drain condensate to the exterior.

A.4 Example: Lower North Shore, NSW

A single storey home in a Lower North Shore suburb of Sydney underwent major renovations that involved extending the ground floor in three directions and the addition of new first floor. The extension was of timber frame construction and pitched tiled roofing.

After the building was closed up and work underway on the interior, damp patches and mould first became apparent on the ceiling and cornices.

Figure A.10



This prompted inspection of the roof space to discover the source of the leaks. When the roof space was investigated the glass fibre insulation at the ceiling level and sections of the plasterboard ceiling were saturated, large beads of condensation were found running down the underside of the foil sarking and mould was evident on structural timber. The moisture content of some of the roof timbers was measured at over 33%.

Figure A.11



Further investigations led to the discovery of more condensate within the walls. It was found that some sections were wrapped with a perforated foil sarking and others with an unperforated foil sarking. On removal of the plasterboard and fibre insulation, condensation was found on the inside face of both types of sarking.

Figure A.12

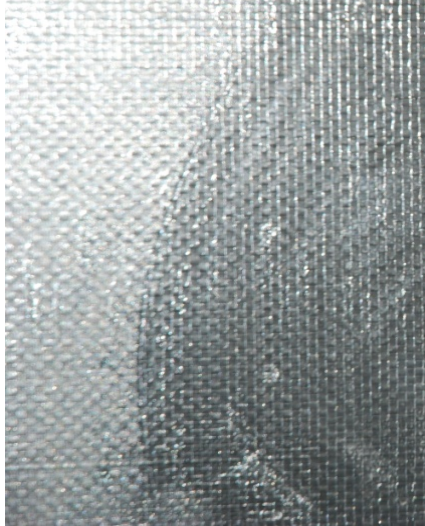

The above images show where the condensation on the right hand side of the image has been wiped off revealing the perforations in the sarking.

The building had no eaves or ridge ventilation in any of the roof sections. The vapour laden air entered the roof space through ceiling penetrations and diffusion through the plasterboard ceiling. Because there was no ventilation the roof space was at a high relative humidity and dew point was reached on the underside of the impermeable foil sarking which was only very slightly above outdoor temperature.

Figure A.13

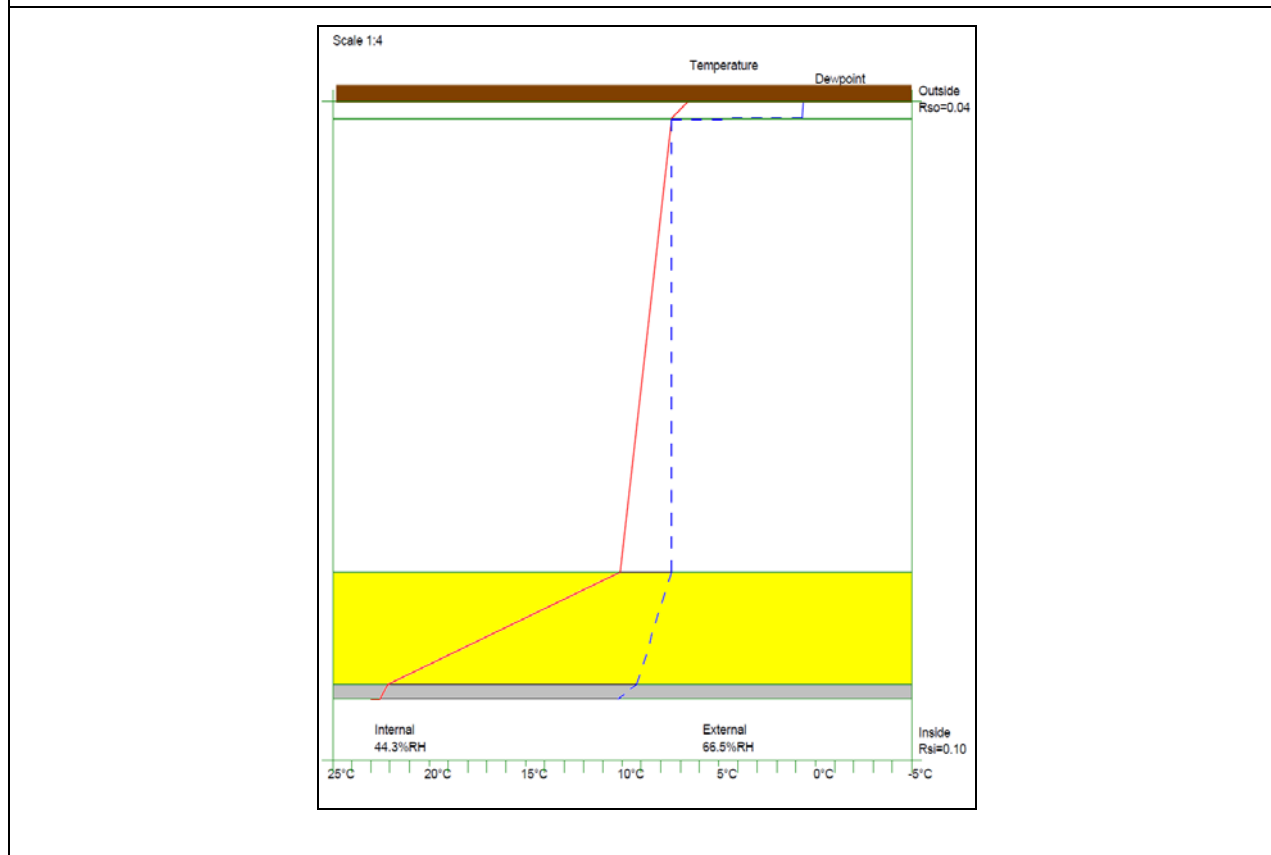

The graph above shows the temperature (red line) and dew point (broken blue line) of this particular roof during the winter. Dew point is reached on the underside of the vapour impermeable foil sarking. The calculation predicted that June would have the most condensation with over 350mL of condensate per square metre.

The condensate ran down the underside of the sarking dripping at some points and collecting and being absorbed by the timber. In particular, the condensate collected at the eaves, where it either was held by the bulk fibre insulation or ran into the wall cavities. The roof space with no provision to dry out developed into a high humidity microclimate.

The main problem was that the building has been well sealed up by the impermeable sarking which was on the cold side exterior side of the insulation. The problem was exacerbated by the micro climate where the presence of ground water, shading from trees and a local topography that contributed to high humidity on winter mornings.

This case study illustrates how the drive for improved energy efficiency has led to reflective foil sarking being used inappropriately on the cold side of the insulation without due consideration for the impact from condensation. Guidance within NCC Volume Two is that “reflective insulation or sarking installed on the cold side of the building should be vapour permeable” and that “in some climate zones, insulation should be installed with due consideration of condensation and associated interaction with adjoining building materials.”

SUMMARY Example: Lower North Shore, NSW

Problem: Mould growth throughout the building, condensate trapped within the walls and roof space, distortion of timber and interior fittings and critically high moisture content of structural roof members.

Location: Lower North Shore, Sydney, NSW – Temperate climate

Cause: Roof space condensation under a fully sarked and unventilated tiled roof during the winter. Condensation also formed on the inside face of perforated and non-perforated foil sarking fixed on the cold side of an insulated timber frame finished with directly fixed rendered fibre cement sheet.

Solution: After completion of remedial work to treat the mould and dry out the building the root cause of the problem needs to be addressed. Either adequate ventilation of the roof space at the eaves and ridge needs to be installed or the impermeable foil sarking should be replaced by an air permeable sarking underlay and a highly vapour permeable sarking underlay.

Common Examples of Intermittent Surface Condensation

In buildings condensation is sometimes visible upon concrete floor slabs in contact with the ground. The surface temperature of concrete floor slabs, in direct contact with the ground, is significantly influenced by soil temperature. Soil temperature tends to follow seasonal average air temperature but lags approximately 30 days behind average trends of air temperature due to the greater heat capacity of the soil. The slab surface can therefore be considerably cooler than indoor air on hot days following a period of cool weather.

A.5 Example: Influence of Air movement combating Surface Condensation

Air is viscous, the viscosity of the air results in a thin air film attached to surfaces. The average temperature is about equal to the average temperature of the surface and the temperature of the main body of surrounding air. This air film offers significant thermal resistance to heat flow when there is no air movement, as indicated by typical values in the table below.

Table A.1 Thermal Resistance of Air Films [no air movement]

Surface Position	Heat Flow Direction	Resistance High Emittance Surface m²·K/W	Resistance Low Emittance Surface m²·K/W
Horizontal	Upward	0.11	0.23
Horizontal	Downward	0.16	0.80
45° Slope	Upward	0.11	0.24
45° Slope	Downward	0.13	0.39
22.5° Slope	Upward	0.11	0.24
22.5° Slope	Downward	0.15	0.60
Vertical	Horizontal	0.12	0.30

The thermal resistance of air films can be significantly reduced by creating air movement across a surface. This is indicated in the table below.

Table A.2 Thermal Resistance of Air Films [with air movement]

Air Movement	Position of Surface	Heat Flow Direction	Resistance m²·K/W
6.00 m/s	Any Position	Any Direction	0.03
3.00 m/s	Any Position	Any Direction	0.04
0.50 m/s	Any Position	Any Direction	0.08

This reduction in the thermal resistance of air films due to air movement can be used to reduce the occurrence of condensation on indoor surfaces. In many cases the minimum temperature of the air film, at the solid surface, is only a fraction of a degree below dew point temperature. This means that if the stagnant air film is disturbed by air movement the temperature of the air adjacent to the cold surface can be raised above dew point temperature.

Figure A.14 Dew point temperature of air

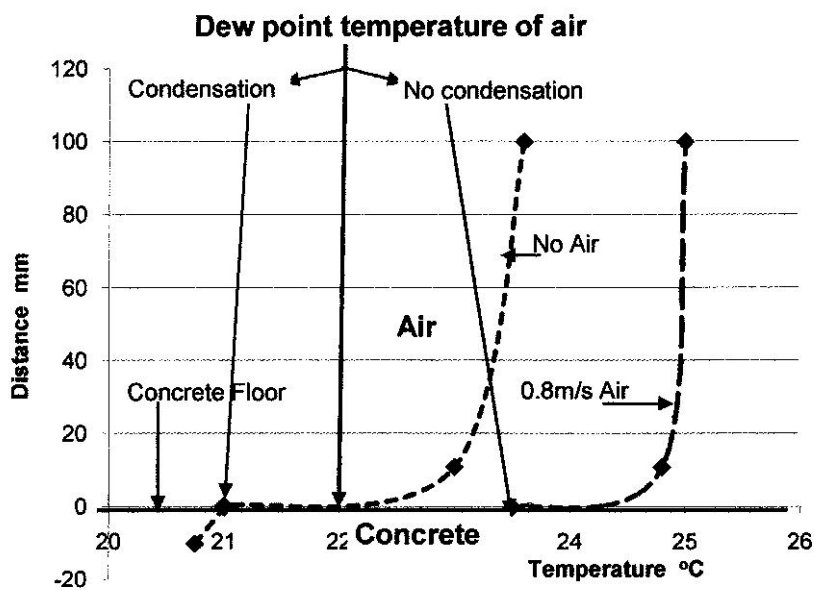

The surface temperatures of concrete floors on grade are influenced by ground temperature which lags behind air temperatures during the increases during springtime. If high humidity occurs during this time condensation can occur on the floor surface. In industrial buildings, such as warehouses there is usually warm air near roof level that can be mixed with cooler air near floor level to create a uniform average air temperature in the space. After the indoor air is mixed this usually increases the temperature in the air film on the floor is enough to avoid surface condensation. Large spaces with high ceilings require large air circulating fans to provide sufficient airflow to be effective over a large floor area.

A.6 Example 5: Humid Tropics

Australia’s humid tropics (BCA climate zone 1) have a warm to hot winterless climate with a wet season during the hotter months. The more populated areas tend to be close to coastline and often benefit from cooling onshore breezes. Shaded outdoor areas are popular for relief from high air temperatures, typically in the low 30’s, with humidity around 65% or more. Dew point temperatures during the day are around 24°C, 5 to 6 degrees below air temperature but as air temperatures fall at night the difference between air temperature and dew point temperature can be less than 2 degrees. It can be illuminating to compare the range of maximum dew point temperatures for location in the various climate zones around Australia (Table A.3). There will be a limited number of occasions when dew point temperatures for a location will be higher than those in Table A.3. For example a limited survey of hourly data for Townsville revealed the following observation on February 3, 2011, at 5:32am the air temperature was 25.3°C with a relative humidity of 99%. This equates to a dew point temperature, T_{dp} °C, of 25.2°C. Such a condition occurs less than 3% of time in that month.

LOCATION	Max T_{dp} °C	Month
Brisbane QLD	19	Jan/Feb
Townsville QLD	24.8	Feb
Weipa QLD	25.3	Feb *highest
Darwin NT	25	Feb/Dec
Katherine NT	24	Jan/Feb
Perth WA	14	Jan
Wyndham WA	24	Feb
Sydney NSW	17	Jan/Feb
Canberra ACT	12	Feb
Melbourne VIC	12	Feb
Adelaide SA	11	Jan/Feb
Cooper Pedy	10	Jan/Feb
Hobart TAS	10	Feb

Table A.3. Maximum Annual Dew Point Temperature from 9am and 3pm data

Indoors many people rely on natural ventilation supplemented by ceiling fans to provide thermal comfort. Newer, more closely spaced, housing on small allotments tends to rely on air conditioning.

Buildings in coastal areas of the humid tropics need to be designed to resist strong winds, airborne debris and flooding from tropical cyclones as well as damage to timber by large termites. Corrugated steel roofing is common as it tends to perform well during tropical cyclones.

Naturally Ventilated houses

Many existing houses in the humid tropics are open planned for natural cross ventilation supplemented by ceiling fans. These buildings tend to be lightweight timber framed construction with careful attention to sun shading. With good exposure to the prevailing breezes they can be quite comfortable. External wall openings are glass louvres, folding walls or French doors. This un-insulated lightweight construction cools down rapidly after sunset. With little temperature difference between outdoor and indoor air temperature the timber walls are not subject to condensation (Figure A.15).

Figure A.15 Temperature profile through an uninsulated wall for naturally ventilated house

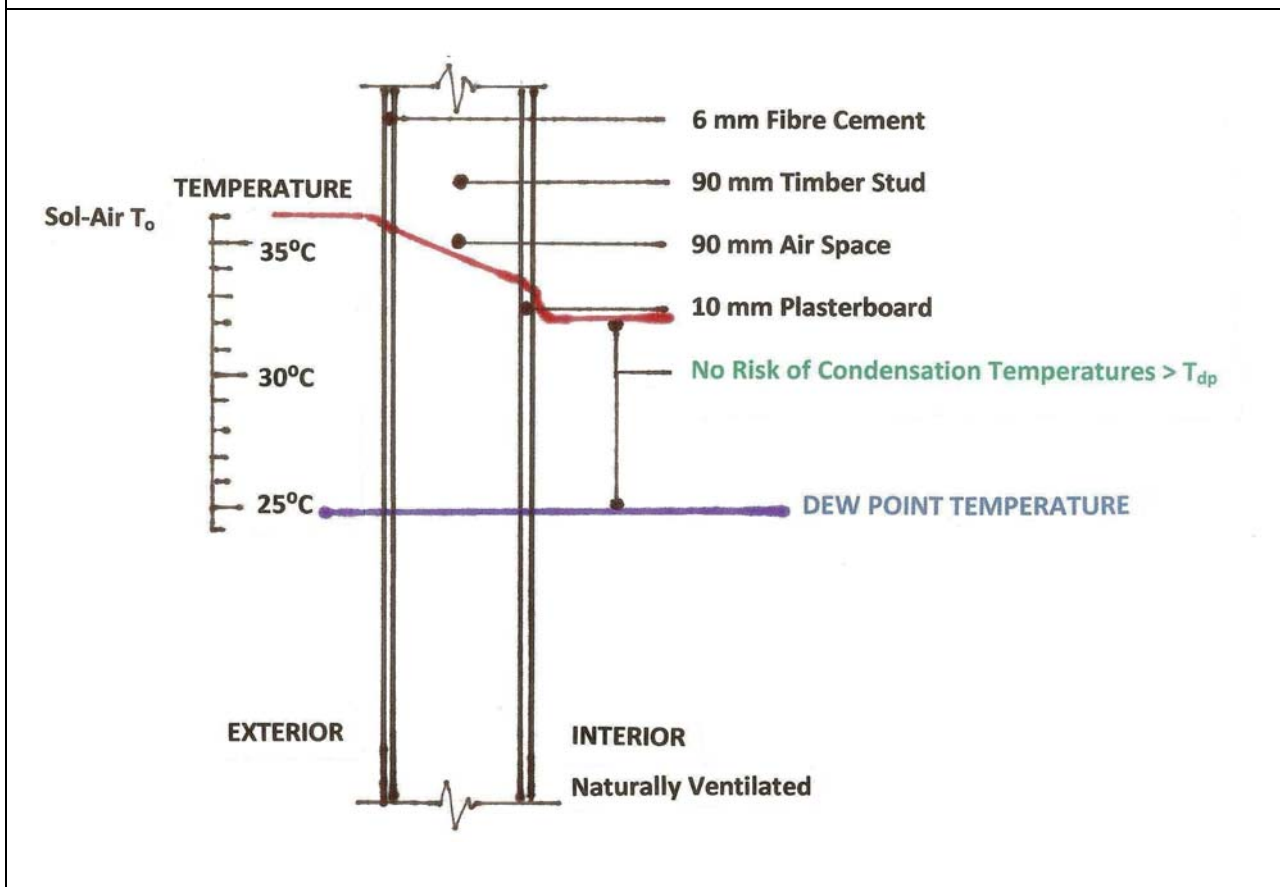

Air conditioning in houses may operate more effectively if the house is insulated. With air conditioning thermostats set below 27°C the inner portions of the walls will be below the dew point temperature creating a risk of condensation. This risk is increased if the building envelope is leaky, allowing outdoor air to enter or if the air conditioning is incapable of maintaining the indoor dew point temperature at or below 13°C. At an indoor 24°C the relative humidity would need to be 50% to achieve a dew point temperature of 13°C (Figure A.16).

An un-insulated metal roof is subject to condensation on a daily basis during the night. The temperature of metal roofs can often fall below the air temperature at night, typically 1°C to 3°C, but under optimum conditions it can be 8°C. This is due to infrared radiant heat loss to the night sky, particularly during calm wind conditions when there are few clouds. Night time air temperatures fall to within 2°C of dew point temperature. This means a metal roof surface, with a temperature say 3°C below air temperature, will be frequently below dew point temperature and condensation will occur on both the upper and lower surfaces of the metal roofing (Figure A.16).

Figure A.16 Sarking under metal roof

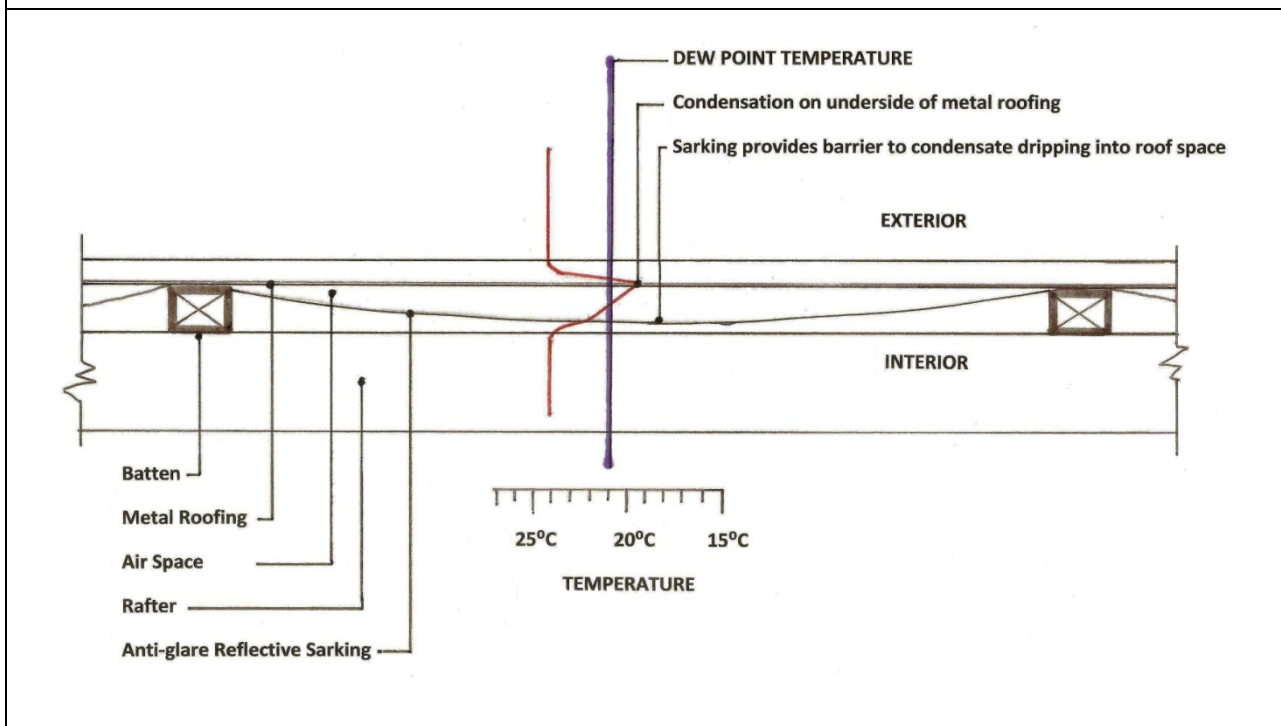

Brick Veneer on Slab

Brick veneer construction is now common in the humid tropics and is similar to that in temperate climate regions. Houses using this construction in new subdivisions are often built close to adjacent houses. This limits the opportunity for natural cross ventilation so most are air conditioned.

During hotter months air conditioner thermostat settings for indoor air temperatures are typically 24°C. With dew point temperature around 25°C there is risk of condensation on plasterboard ceilings and walls and within wall insulation in poorly sealed buildings and with air conditioning with limited humidity control (Figure A.17). Shaded walls have cooler internal temperatures that increase the risk of condensation slightly.

Figure A.17 Brick veneer wall

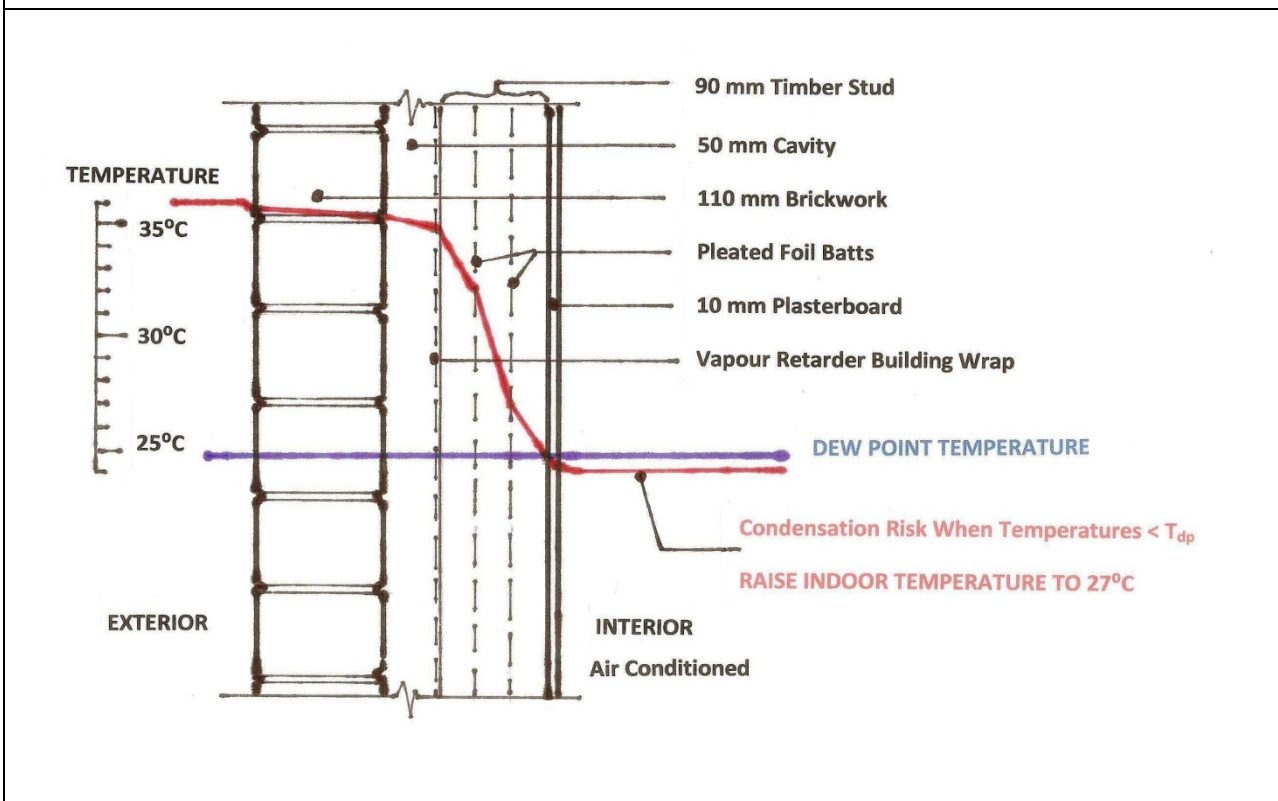

Concrete Masonry

Concrete masonry is termite resistant and, unlike other masonry, is intentionally designed so that it can be reinforced with steel bars to resist debris impact and uplift forces on roofs during tropical cyclones. The downside is that if reinforced concrete masonry is directly exposed to solar radiation it has a large capacity to absorb and store heat and moisture (hygric buffer capacity, Lstburek, 2002). However, if concrete masonry is only exposed to interior spaces and thermally insulated on the exterior surfaces it provides storage of cool rather than heat in air conditioned space (Figure A.18).

Figure A.18 Concrete masonry wall with external insulation

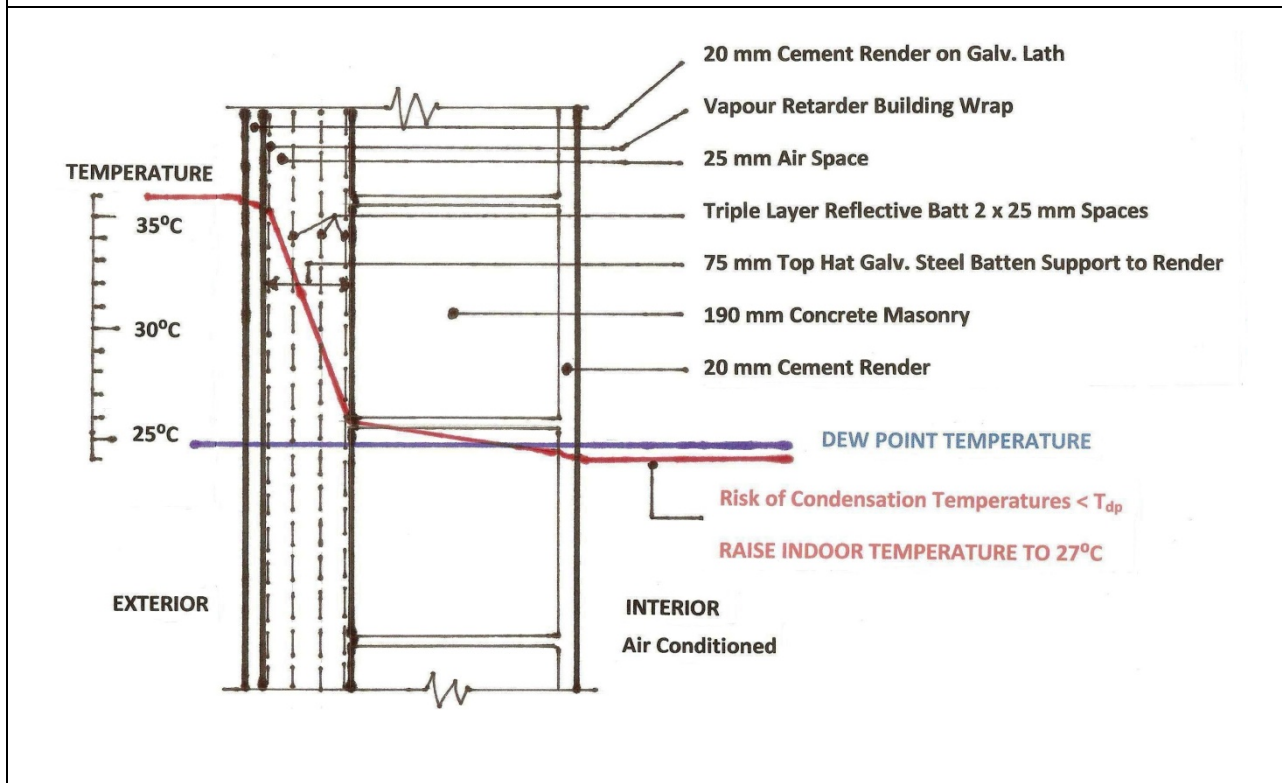

House Roofs

It is very difficult to seal walls and roofs against infiltration of outdoor air into a building. Air movement through walls and roofs carries with it large quantities of water vapour in humid tropical regions. This can contribute to the risk of indoor condensation on cool surfaces during periods of high humidity but infiltration also removes moisture stored in materials during drier periods. A simple strategy to avoid indoor condensation in air conditioned space is to ensure that indoor surface temperatures are above dew point temperature.

A.7 Examples: Condensation in Commercial and Industrial buildings

Walls

Condensation is an issue in the design of curtain wall systems in commercial buildings in humid tropical regions. Precision manufacture of curtain wall components makes it more feasible to incorporate air barriers, vapour barriers or retarders and drainage planes and thermal insulation within the narrow profile of curtain walls. However, the principal strategy to avoid condensation in air conditioned commercial buildings in humid tropical regions is to ensure that the capacity of the air conditioning system can maintain indoor humidity so that the indoor dew point temperature does not exceed 13°C. This is the practice in the humid tropics in the USA.

At an indoor 24°C the relative humidity would need to be 50% to achieve a dew point temperature of 13°C. At an indoor 27°C the relative humidity would need to be 42% to achieve a dew point temperature of 13°C.

Walls of industrial buildings in the humid tropics are typically light gauge steel on steel framing and are rarely insulated because they are naturally ventilated and not normally air conditioned. The exterior colour of these walls is usually solar reflective to reduce sol-air temperatures and shaded when possible. Because there is little temperature difference between indoor and outdoor air temperatures the risk of condensation in or on walls is low.

Roofs

Roofs present the most common risk of condensation in air conditioned commercial buildings in the humid tropics. This is because most roof surfaces are low pitch metal and experience temperatures below dew point temperature over night due to radiant heat loss to the sky. In metal framed roofs it is important to provide thermal separation between the roofing metal and the framing below. If this is not done thermal bridging will result in the temperature of the roof purlins or battens falling to the same temperature as the roof and become secondary locations for condensation. Drainage of condensation on top of sarking from the underside of low pitched metal roofing is more difficult. Sarking, at a low pitch, needs continuous support to avoid ponding of condensate in depressions of the sarking between supporting purlins or battens. Also sealing of the roof space between roof insulation and ceilings above offices can be difficult. If humid outdoor air has free entry into such a roof space condensation will occur on air conditioning ductwork and ceilings above offices.

Metal roofs of industrial buildings experience similar overnight temperature to commercial buildings and require careful attention drainage of condensation from sarking. Any leaks of condensate through sarking are likely to compromise thermal insulation and result in corrosion of metal roof components or rotting of timber members. As most industrial buildings are not air conditioned daytime temperature in roof construction is higher than dew point temperature so condensation is not normally a problem during that time.

Reference

Lstburek, J. (2002) Moisture control for buildings, *ASHRAE Journal*, Feb., pp. 36-41

Appendix B: Examples of Risk Analysis

Figure B.19 Precise numerical values for dew point temperatures

LOOK - UP TABLE FOR DEW POINT TEMPERATURE for Dry Bulb 0 to 40°C and Relative Humidity 10% to 100%																																								
T _{DB} °C	0	2	4	6	8	10	11	12	13	14	15	16	17	18	19	20	21	22	23	24	25	26	27	28	29	30	32	34	36	38	40									
RH 10%	-25.4	-23.9	-22.5	-21.0	-19.6	-18.2	-17.5	-16.8	-16.1	-15.4	-14.7	-14.0	-13.3	-12.6	-11.9	-11.2	-10.5	-9.8	-9.1	-8.5	-7.8	-7.1	-6.4	-5.7	-5.1	-4.4	-3.0	-1.7	-0.4	1.1	2.6									
12%	-23.5	-22.1	-20.6	-19.2	-17.7	-16.3	-15.5	-14.8	-14.1	-13.4	-12.7	-12.0	-11.3	-10.6	-9.9	-9.2	-8.5	-7.8	-7.1	-6.4	-5.7	-5.0	-4.3	-3.6	-2.9	-2.2	-0.9	0.6	2.2	3.7	5.2									
14%	-22.0	-20.5	-19.0	-17.5	-16.1	-14.6	-13.9	-13.1	-12.4	-11.7	-11.0	-10.3	-9.5	-8.8	-8.1	-7.4	-6.7	-6.0	-5.3	-4.6	-3.9	-3.2	-2.5	-1.8	-1.1	-0.4	1.2	2.8	4.3	5.9	7.5									
16%	-20.6	-19.1	-17.6	-16.1	-14.6	-13.1	-12.4	-11.7	-11.0	-10.2	-9.5	-8.8	-8.0	-7.3	-6.6	-5.9	-5.1	-4.4	-3.7	-3.0	-2.3	-1.6	-0.9	-0.2	0.7	1.5	3.1	4.7	6.2	7.8	9.4									
18%	-19.4	-17.8	-16.3	-14.8	-13.3	-11.8	-11.1	-10.4	9.6	-8.9	-8.1	-7.4	-6.7	-5.9	-5.2	-4.5	-3.8	-3.0	-2.3	-1.6	-0.9	-0.1	0.7	1.5	2.3	3.1	4.7	6.4	8.0	9.6	11.2									
20%	-18.3	-16.7	-15.2	-13.7	-12.2	-10.7	9.9	-9.2	-8.4	-7.7	-6.9	-6.2	-5.4	-4.7	-4.0	-3.2	-2.5	-1.8	-1.0	-0.3	0.5	1.3	2.1	3.0	3.8	4.6	6.3	7.9	9.5	11.2	12.8									
22%	-17.2	-15.7	-14.2	-12.6	-11.1	-9.6	-8.8	-8.1	-7.3	-6.6	-5.8	-5.1	-4.3	-3.6	-2.8	-2.1	-1.4	-0.6	0.2	1.0	1.8	2.7	3.5	4.3	5.2	6.0	7.6	9.3	10.9	12.6	14.2									
24%	-16.3	-14.9	-13.2	-11.7	-10.1	-8.6	-7.8	-7.1	-6.3	-5.6	-4.8	-4.1	-3.3	-2.6	-1.9	-1.1	-0.3	0.5	1.4	2.2	3.0	3.9	4.7	5.6	6.4	7.2	8.9	10.6	12.3	13.9	15.6									
26%	-15.5	-13.9	-12.3	-10.8	-9.2	-7.7	-6.9	-6.2	-5.4	-4.6	-3.9	-3.1	-2.4	-1.6	-0.8	-0.1	0.8	1.6	2.5	3.3	4.2	5.0	5.9	6.7	7.6	8.4	10.1	11.8	13.5	15.2	16.9									
28%	-14.6	-13.1	-11.5	-9.9	-8.4	-6.8	-6.1	-5.3	-4.5	-3.8	-3.0	-2.2	-1.5	-0.7	0.1	1.0	1.8	2.7	3.5	4.5	5.2	6.1	7.0	7.8	8.7	9.5	11.2	12.9	14.6	16.3	18.0									
30%	-13.9	-12.3	-10.7	-9.2	-7.6	-6.0	-5.3	-4.5	-3.7	-2.9	-2.2	-1.4	-0.6	0.2	1.0	1.9	2.8	3.6	4.5	5.4	6.2	7.1	8.0	8.8	9.7	10.5	12.3	14.0	15.7	17.4	19.1									
32%	-13.2	-11.6	-10.0	-8.4	-6.9	-5.3	-4.5	-3.7	-3.0	-2.2	-1.4	-0.6	0.2	1.1	1.9	2.8	3.7	4.6	5.4	6.3	7.2	8.0	8.9	9.8	10.7	11.5	13.3	15.0	16.7	18.4	20.2									
34%	-12.5	-10.9	-9.3	-7.7	-6.2	-4.6	-3.8	-3.0	-2.2	-1.4	-0.7	0.2	1.0	1.9	2.8	3.7	4.6	5.4	6.3	7.2	8.1	8.9	9.8	10.7	11.6	12.4	14.2	15.9	17.7	19.4	21.1									
36%	-11.9	-10.3	-8.7	-7.1	-5.5	-3.9	-3.1	-2.3	-1.5	-0.8	0.1	0.9	1.8	2.7	3.6	4.5	5.4	6.3	7.1	8.0	8.9	9.8	10.7	11.6	12.4	13.3	15.1	16.8	18.6	20.3	22.1									
38%	-11.3	-9.7	-8.1	-6.5	-4.9	-3.3	-2.5	-1.7	-0.9	-0.1	0.8	1.7	2.6	3.5	4.4	5.3	6.2	7.0	7.9	8.8	9.7	10.6	11.5	12.4	13.3	14.1	15.9	17.7	19.4	21.2	23.0									
40%	-10.7	-9.1	-7.5	-5.9	-4.3	-2.7	-1.9	-1.1	-0.3	0.6	1.5	2.4	3.3	4.2	5.1	6.0	6.9	7.8	8.7	9.6	10.5	11.4	12.3	13.2	14.0	14.9	16.7	18.5	20.3	22.0	23.8									
42%	-10.0	-8.5	-6.9	-5.3	-3.7	-2.1	-1.3	-0.5	0.4	1.3	2.2	3.1	4.0	4.9	5.8	6.7	7.6	8.5	9.4	10.3	11.2	12.1	13.0	13.9	14.8	15.7	17.5	19.3	21.1	22.9	24.6									
44%	-1.0	-8.0	-6.4	-4.7	-3.1	-1.5	-0.7	0.1	1.0	1.9	2.9	3.8	4.7	5.6	6.5	7.4	8.3	9.2	10.1	11.0	11.9	12.8	13.7	14.6	15.5	16.4	18.2	20.0	21.8	23.6	25.4									
46%	-9.1	-7.5	-5.9	-4.2	-2.6	-1.0	-0.2	0.7	1.7	2.6	3.5	4.4	5.3	6.2	7.1	8.0	9.0	9.9	10.8	11.7	12.6	13.5	14.4	15.3	16.2	17.1	18.9	20.7	22.6	24.4	26.2									
48%	-8.7	-7.0	-5.4	-3.7	-2.1	-0.5	0.4	1.3	2.3	3.2	4.1	5.0	5.9	6.8	7.8	8.7	9.6	10.5	11.4	12.3	13.2	14.2	15.1	16.0	16.9	17.8	19.6	21.4	23.3	25.1	26.9									
50%	-8.2	-6.5	-4.9	-3.2	-1.6	0.1	1.0	1.9	2.8	3.8	4.7	5.6	6.5	7.4	8.4	9.3	10.2	11.1	12.0	12.9	13.9	14.8	15.7	16.6	17.5	18.4	20.3	22.1	23.9	25.8	27.6									
52%	-7.7	-6.1	-4.4	-2.8	-1.1	0.6	1.5	2.5	3.4	4.3	5.2	6.2	7.1	8.0	8.9	9.9	10.8	11.7	12.6	13.5	14.5	15.4	16.3	17.2	18.2	19.1	20.9	22.8	24.6	26.4	28.3									
54%	-7.3	-5.6	-4.0	-2.3	-0.7	1.1	2.1	3.0	3.9	4.8	5.8	6.7	7.6	8.6	9.5	10.4	11.3	12.3	13.2	14.1	15.1	16.0	16.9	17.8	18.8	19.7	21.5	23.4	25.2	27.1	28.9									
56%	-6.9	-5.2	-3.6	-1.9	-0.2	1.6	2.6	3.5	4.4	5.4	6.3	7.2	8.2	9.1	10.0	11.0	11.9	12.8	13.8	14.7	15.6	16.6	17.5	18.4	19.3	20.3	22.1	24.0	25.8	27.7	29.5									
58%	-6.5	-4.8	-3.1	-1.5	0.2	2.1	3.1	4.0	4.9	5.9	6.8	7.7	8.7	9.6	10.6	11.5	12.4	13.4	14.3	15.2	16.2	17.1	18.0	19.0	19.9	20.8	22.7	24.6	26.4	28.3	30.1									
60%	-6.1	-4.4	-2.7	-1.1	0.7	2.6	3.5	4.5	5.4	6.4	7.3	8.2	9.2	10.1	11.1	12.0	12.9	13.9	14.8	15.8	16.7	17.6	18.6	19.5	20.5	21.4	23.3	25.1	27.0	28.9	30.7									
62%	-5.7	-4.0	-2.3	-0.7	1.2	3.1	4.0	5.0	5.9	6.8	7.8	8.7	9.7	10.6	11.6	12.5	13.4	14.4	15.3	16.3	17.2	18.2	19.1	20.0	21.0	21.9	23.8	25.7	27.6	29.4	31.3									
64%	-5.3	-3.7	-2.0	-0.3	1.6	3.5	4.5	5.4	6.4	7.3	8.3	9.2	10.1	11.1	12.0	13.0	13.9	14.9	15.8	16.8	17.7	18.7	19.6	20.6	21.5	22.4	24.3	26.2	28.1	30.0	31.9									
66%	-5.0	-3.3	-1.6	0.1	2.0	3.9	4.9	5.9	6.8	7.8	8.7	9.7	10.6	11.6	12.5	13.5	14.4	15.4	16.3	17.3	18.2	19.2	20.1	21.1	22.0	23.0	24.8	26.7	28.6	30.5	32.4									
68%	-4.6	-2.9	-1.2	0.5	2.5	4.4	5.3	6.3	7.2	8.2	9.1	10.1	11.1	12.0	13.0	13.9	14.9	15.8	16.8	17.7	18.7	19.6	20.6	21.5	22.5	23.4	25.3	27.3	29.2	31.1	33.0									
70%	-4.3	-2.6	-0.9	0.9	2.9	4.8	5.7	6.7	7.7	8.6	9.6	10.5	11.5	12.5	13.4	14.4	15.3	16.3	17.2	18.2	19.1	20.1	21.1	22.0	23.0	23.9	25.8	27.7	29.7	31.6	33.5									
72%	-4.0	-2.3	-0.5	1.3	3.3	5.2	6.2	7.1	8.1	9.0	10.0	11.0	11.9	12.9	13.8	14.8	15.8	16.7	17.7	18.6	19.6	20.6	21.5	22.5	23.4	24.4	26.3	28.2	30.1	32.1	34.0									
74%	-3.6	-1.9	-0.2	1.7	3.7	5.6	6.5	7.5	8.5	9.4	10.4	11.4	12.3	13.3	14.3	15.2	16.2	17.2	18.1	19.1	20.0	21.0	22.0	23.0	23.9	24.9	26.8	28.7	30.6	32.5	34.5									
76%	-3.3	-1.6	0.2	2.1	4.0	6.0	6.9	7.9	8.9	9.8	10.8	11.8	12.7	13.7	14.7	15.6	16.6	17.6	18.5	19.5	20.5	21.4	22.4	23.4	24.3	25.3	27.2	29.2	31.1	33.0	34.9									
78%	-3.0	-1.3	0.5	2.5	4.4	6.3	7.3	8.3	9.3	10.2	11.2	12.2	13.1	14.1	15.1	16.1	17.0	18.0	19.0	19.9	20.9	21.9	22.8	23.8	24.8	25.7	27.7	29.6	31.5	33.5	35.4									
80%	-2.7	-1.0	0.9	2.8	4.8	6.7	7.7	8.7	9.6	10.6	11.6	12.6	13.5	14.5	15.5	16.4	17.4	18.4	19.4	20.3	21.3	22.3	23.3	24.2	25.2	26.2	28.1	30.1	32.0	33.9	35.9									
82%	-2.4	-0.7	1.2	3.2	5.1	7.1	8.0	9.0	10.0	11.0	12.0	12.9	13.9	14.9	15.9	16.8	17.8	18.8	19.8	20.7	21.7	22.7	23.7	24.6	25.6	26.6	28.5	30.5	32.4	34.4	36.3									
84%	-2.1	-0.4	1.5	3.5	5.5	7.4	8.4	9.4	10.4	11.3	12.3	13.3	14.3	15.3	16.2	17.2	18.2	19.2	20.2	21.1	22.1	23.1	24.1	25.0	26.0	27.0	29.0	30.9	32.9	34.8	36.8									
86%	-1.8	-0.1	1.9	3.8	5.8	7.8	8.8	9.7	10.7	11.7	12.7	13.7	14.6	15.6	16.6	17.6	18.6	19.6	20.5	21.5	22.5	23.5	24.5	25.4	26.4	27.4	29.4	31.3	33.3	35.2	37.2									
88%	-1.6	0.2	2.2	4.2	6.1	8.1	9.1	10.1	11.1	12.0	13.0	14.0	15.0	16.0	17.0	18.0	18.9	19.9	20.9	21.9	22.9	23.9	24.8	25.8	26.8	27.8	29.8	31.7	33.7	35.7	37.6									
90%	-1.3	0.5	2.5	4.5	6.5	8.4	9.4	10.4	11.4	12.4	13.4	14.4	15.3	16.3	17.3	18.3	19.3	20.3	21.3	22.3	23.2	24.2	25.2	26.2	27.2	28.2	30.1	32.1	34.1	36.1	38.0									
92%	-1.0	0.8	2.8	4.8	6.8	8.8	9.8	10.7	11.7	12.7	13.7	14.7	15.7	16.7	17.7	18.7	19.7	20.6	21.6	22.6	23.6	24.6	25.6	26.6	27.6	28.6	30.5	32.5	34.5	36.5	38.4									
94%	-0.8	1.1	3.1	5.1	7.1	9.1	10.1	11.1	12.1	13.1																														

Building Envelope: A brick veneer construction with a 10mm plasterboard lining, R2.0 fibre insulation bats, a reflective vapour permeable (breathable) membrane on the exterior of the frame with a vapour resistance of 2.1MNs/g and an anti-glare surface with an emissivity of 0.2, and an unventilated cavity.

Figure B.2 Material properties of building materials listed in order from exterior to interior

<i>Construction</i>	Thickness (mm)	Thermal Conductivity (W/mK)	Thermal Resistance (m ² K/W)	Vapour Resistivity (MNs/gm)	Vapour Resistance (MNs/g)
Outside surface resistance	-	-	0.040	-	-
110mm Brickwork	110.0	0.611	0.180	50.00	5.50
Reflective Unvented Cavity	50.0	-	0.490	-	0.00
Reflective vapour permeable (breathable) membrane (2.1MNs/g)	0.4	0.000	0.000	-	2.10
R2 Glass fibre insulation batt	90.0	0.045	2.000	5.00	0.45
Plasterboard	10.0	0.170	0.059	45.00	0.45
Inside surface resistance	-	-	0.120	-	-

Figure B.3 Condensation Risk Analysis

Condensation Risk Analysis (no account taken of thermal bridges)							
Internal / External Conditions : 23.0°C @ 54.7%RH / 6.0°C @ 70.0%RH Buildup period 31 days							
	Interface Temp. °C	Dewpoint Temp. °C	Vapour Pressure (kPa)	Saturated V.P. (kPa)	Winter Buildup (g/m ²)	Annual Buildup (g/m ²)	Conden- sation
1 Outside surface resistance	6.2	0.9	0.65	0.95	-	-	No
2 110mm Brickwork	7.3	7.3	1.02	1.02	102	-132	Yes
3 Reflective Unvented Cavity	10.2	7.3	1.02	1.24	-	-	No
4 Reflective vapour permeable (breathable) membrane (2.1MNs/g)	10.2	10.2	1.24	1.24	594	-1371	Yes
5 R2 Glass fibre insulation batt	21.9	11.9	1.39	2.63	-	-	No
6 Plasterboard	22.3	13.4	1.54	2.69	-	-	No
7 Inside surface resistance							

Figure B.4

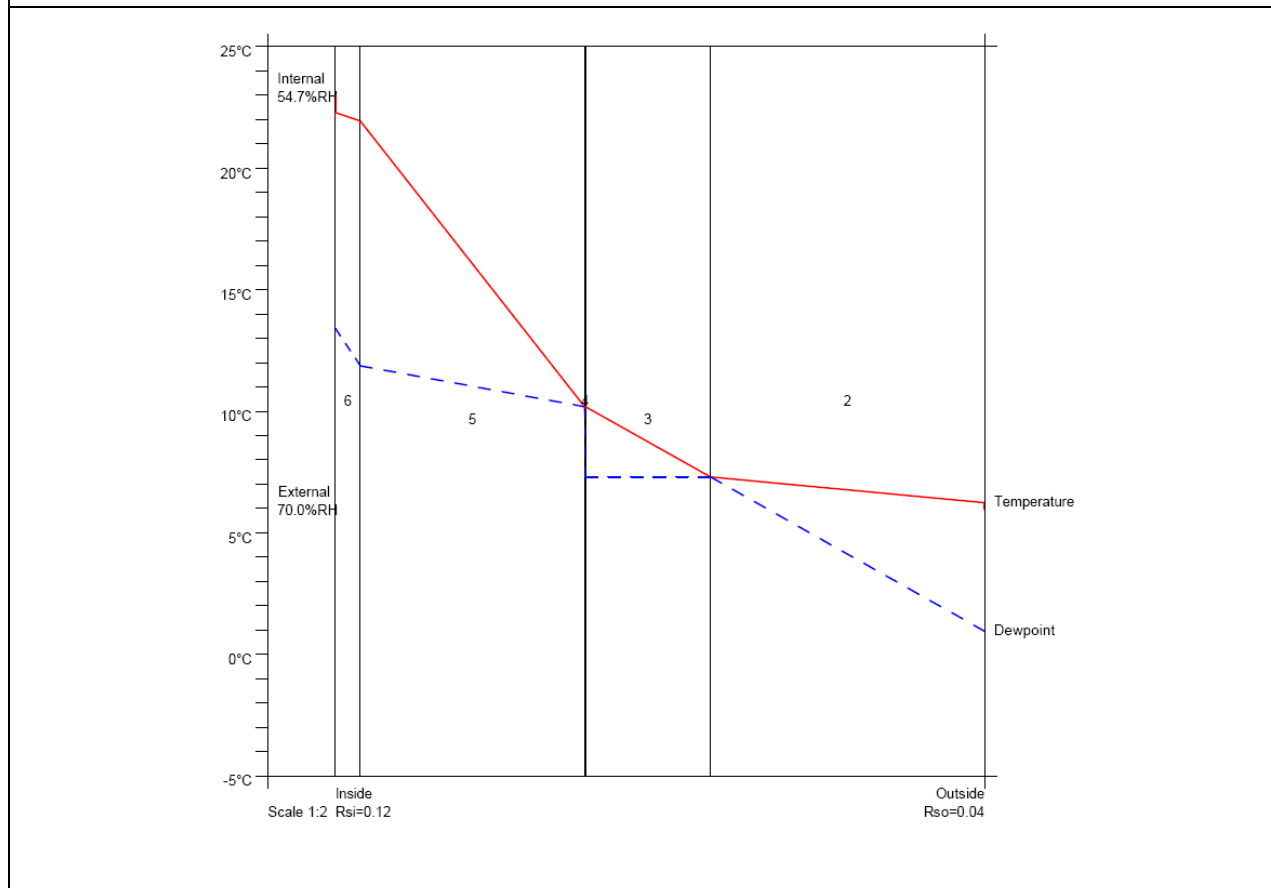

The above table and graph show the dry bulb temperature (solid line) and dew point (broken line) at the interface between the materials in the building envelope described above. The results predict that condensation will form at the interface between the reflective vapour permeable (breathable) membrane and the bulk insulation. Although the annual build up is negative, condensation might build up throughout the winter for long enough to cause problems particularly if the condensate runs down inside of wall collecting in larger volumes.

Example B.2 of Steady State Condensation Risk Analysis

Construction Type: Brick Vener Construction with non reflective vapour permeable (breathable) membrane - vapour resistance of 0.13MNs/g

Exterior Climate: Cold or temperate climate zone (6.0°C and 70% relative humidity)

Interior Conditions: Low occupancy residential building (23.0°C and 54.7% relative humidity)

Building Envelope: A brick veneer construction with a 10mm plasterboard lining, R2.0 fibre insulation bats, a non reflective vapour permeable (breathable) membrane on the exterior of the frame with a vapour resistance of 0.13MNs/g and an unventilated, unreflective cavity

Figure B.5 Material properties of building materials listed in order from exterior to interior

<i>Construction</i>	Thickness (mm)	Thermal Conductivity (W/mK)	Thermal Resistance (m ² K/W)	Vapour Resistivity (MNs/gm)	Vapour Resistance (MNs/g)
Outside surface resistance	-	-	0.040	-	-
110mm Brickwork	110.0	0.611	0.180	50.00	5.50
Non-reflective Unvented Cavity	50.0	-	0.200	-	0.00
Vapour permeable (breathable) membrane (0.13MNs/g)	0.5	-	0.000	-	0.13
R2 Glass fibre insulation batt	90.0	0.045	2.000	5.00	0.45
Plasterboard	10.0	0.170	0.059	45.00	0.45
Inside surface resistance	-	-	0.120	-	-

Figure B.6 Condensation Risk Analysis

Condensation Risk Analysis (no account taken of thermal bridges)
Internal / External Conditions : 23.0°C @ 54.7%RH / 6.0°C @ 70.0%RH Buildup period 31 days

	Interface Temp. °C	Dewpoint Temp. °C	Vapour Pressure (kPa)	Saturated V.P. (kPa)	Winter Buildup (g/m ²)	Annual Buildup (g/m ²)	Conden- sation
1 Outside surface resistance	6.3	0.9	0.65	0.95	-	-	No
2 110mm Brickwork	7.4	7.4	1.03	1.03	1127	-644	Yes
3 Non-reflective Unvented Cavity	8.7	7.4	1.03	1.13	-	-	No
4 Vapour permeable (breathable) membrane (0.13MNs/g)	8.7	8.3	1.10	1.13	-	-	No
5 R2 Glass fibre insulation batt	21.8	11.1	1.32	2.62	-	-	No
6 Plasterboard	22.2	13.4	1.54	2.68	-	-	No
7 Inside surface resistance							

Figure B.7

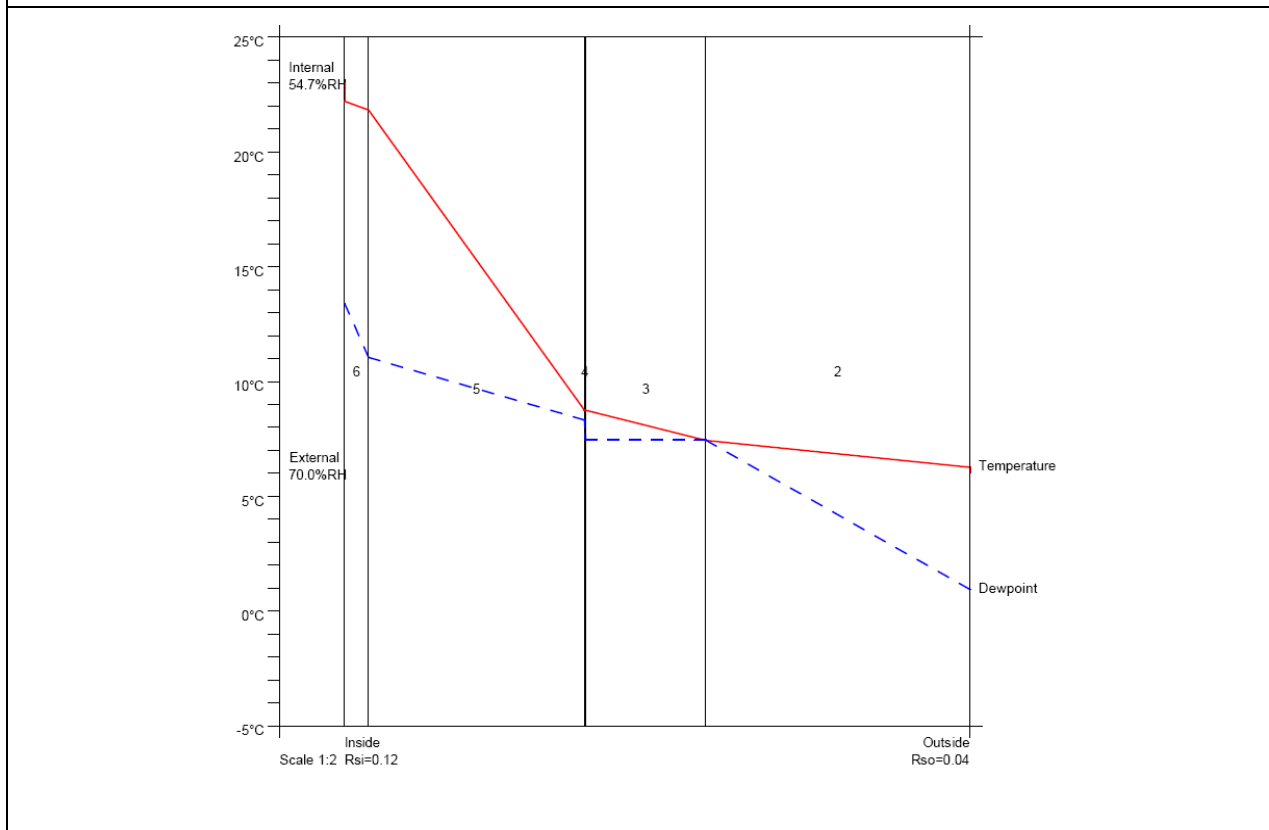

The above table and graph show the dry bulb temperature (solid line) and dew point (broken line) at the interface between the materials in the building envelope described above. The results indicate that the introduction of a vapour permeable membrane with a sufficiently low vapour resistance means that dew point is predicted to form external to the sarking.

Example B.3 of Steady State Condensation Risk Analysis

Construction Type: Brick Veneer Construction with a reflective vapour permeable (breathable) membrane - vapour resistance of 0.60MNs/g.

Exterior Climate: Cold or temperate climate zone (6.0°C and 70% relative humidity)

Interior Conditions: Low occupancy residential building (23.0°C and 54.7% relative humidity)

Building Envelope: A brick veneer construction with a 10mm plasterboard lining, R2.0 fibre insulation bats, a reflective vapour permeable (breathable) membrane on the exterior of the frame with a vapour resistance of 0.60MNs/g and an anti-glare surface with an emissivity of 0.2, and an unventilated cavity.

Figure B.8 Material properties of building materials listed in order from exterior to interior

<i>Construction</i>	Thickness (mm)	Thermal Conductivity (W/mK)	Thermal Resistance (m ² K/W)	Vapour Resistivity (MN _s /gm)	Vapour Resistance (MN _s /g)
Outside surface resistance	-	-	0.040	-	-
110mm Brickwork	110.0	0.611	0.180	50.00	5.50
Reflective Unvented Cavity	50.0	-	0.490	-	0.00
Reflective vapour permeable (breathable) membrane (0.60MN _s /g)	0.4	0.000	0.000	-	0.60
R2 Glass fibre insulation batt	90.0	0.045	2.000	5.00	0.45
Plasterboard	10.0	0.170	0.059	45.00	0.45
Inside surface resistance	-	-	0.120	-	-

Figure B.9 Condensation Risk Analysis

Condensation Risk Analysis (no account taken of thermal bridges)
Internal / External Conditions : 23.0°C @ 54.7%RH / 6.0°C @ 70.0%RH Buildup period 31 days

	Interface Temp. °C	Dewpoint Temp. °C	Vapour Pressure (kPa)	Saturated V.P. (kPa)	Winter Buildup (g/m ²)	Annual Buildup (g/m ²)	Conden- sation
1 Outside surface resistance	6.2	0.9	0.65	0.95	-	-	No
2 110mm Brickwork	7.3	7.3	1.02	1.02	739	-1251	Yes
3 Reflective Unvented Cavity	10.2	7.3	1.02	1.24	-	-	No
4 Reflective vapour permeable (breathable) membrane (0.60MN _s /g)	10.2	10.0	1.23	1.24	-	-	No
5 R2 Glass fibre insulation batt	21.9	11.8	1.38	2.63	-	-	No
6 Plasterboard	22.3	13.4	1.54	2.69	-	-	No
7 Inside surface resistance							

Figure B.10

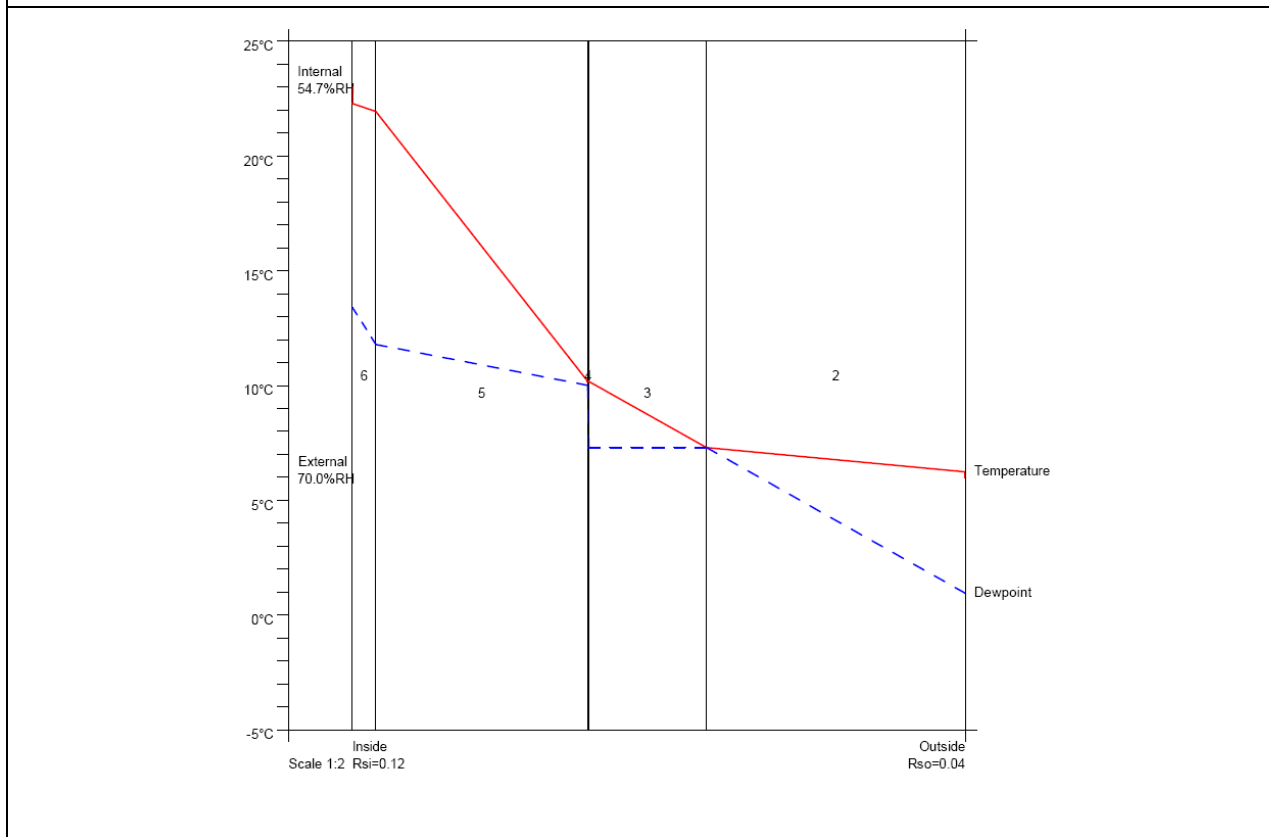

The above table and graph show the dry bulb temperature (solid line) and dew point (broken line) at the interface between the materials in the building envelope described above. The results indicate that the introduction of a vapour permeable membrane with a sufficiently low vapour resistance means that dew point is predicted to form external to the sarking.

A comparison of these three condensation risk analysis for almost identical designs, highlights the importance of knowing and specifying the maximum vapour resistance of the sarking and also that the placement of insulation and reflective air spaces can impact on where dew point occurs.

B.4 Example of Steady State Condensation Risk Analysis

Figure B.11

CRITICAL HUMIDITY FOR SUMMER CONDENSATION ON A WAREHOUSE WALL

Evaluation for Summer, 30°C ambient air temperature, 24°C inside air temperature.

Wall element:	Rvalue m ² .K/W	Inner surface °C	Element mean °C	Outer surface °C	Δt
Indoor air film (reflective surface):	0.300	24.0	24.3	24.6	0.6
Reflective foil insulation:	0.000	24.6	24.6	24.6	0.0
R2 (75mm 20kg/m ³) glasswool:	1.971	24.6	26.7	28.8	4.2
Reflective vapour barrier:	0.000	28.8	28.8	28.8	0.0
Reflective 15mm air gap:	0.500	28.8	29.4	29.9	1.1
Colorbond metal wall:	0.000	29.9	29.9	29.9	0.0
Outdoor air film (unreflective surface):	0.040	29.9	30.0	30.0	0.1
Total R:	2.81	m ² .K/W.			6.0

vapour tries to move from warm to cold

NOTES:

Determinations based upon AS/NZS 4859.1:2002/Amdt 1 2006
 Calculation by the Thermal Gradient Method by James Fricker, F.AIRAH, M.IEAust, CPEng.

CONCLUSION:

For summer case, condensation attempts to occur on outer (warm-side) surfaces.

For the above wall system, and provided the vapour barrier is intact, the outdoor dewpoint must be less than 28.8°C to prevent condensation.

30°C dry bulb, 28.8°dewpoint corresponds to 93.8% RH

Condensation will occur on outer cavity RFL surface if the outdoor humidity is above 93.8%



Appendix C Supplementary Material

C.1 Useful values for thermal conductivity and vapour resistance

The tables below have been extracted from annex C of BS5250:2002 and have been reproduced with kind permission from British Standards.

Other useful sources for this information are AIRAH, ASHRAE Handbook – Fundamentals Chapters 23 and 25, building science textbooks, and test data supplied by manufacturers.

Figure C.1

Annex C (normative)
Material properties

Table C.1 gives the thermal conductivity and vapour resistivity of a range of important building materials. These values of material properties should be combined with component dimensions to give the thermal and vapour resistances that are used in calculations. Further data are given in CIBSE Guide A3 [15] and BS EN 12524.

NOTE The values given in this table are the best currently available. However, data from measurements, independent certification or manufacturers' literature should be used wherever possible.

Table C.1 — Thermal conductivities and vapour resistivities

Material	Density kg/m ³	Thermal conductivity W/m·K	Vapour resistivity	
			Typical MN·s/g·m	Range MN·s/g·m
Airspace		See Table C.3	See Note 1	
Asbestos cement sheeting and substitutes	700	0.36	300	200 to 1 000
Asphalt (poured)	2 100	1.20	—	—
Bitumen	1 000	0.20	10 000	2 000 to 60 000
Blockwork				
lightweight	600	0.22	30	20 to 50
medium weight	1 400	0.60	50	30 to 80
dense	2 050	0.90	100	60 to 150
Brickwork				
common/inner leaf	1 700	0.62	50	25 to 100
common/outer leaf	1 700	0.84	50	25 to 100
engineering	2 000	1.25	120	100 to 250
Carpeting				
with cellular rubber underlay	400	0.10	200	100 to 300
with synthetic underlay	160	0.06	200	100 to 300
Concrete (cast)				
aerated, cellular	400	0.15	50	
aerated	850	0.29	100	
medium weight	1 350	0.59	150	
dense	2 200	1.70	200	
no fines	1 800	0.96	20	
Fibre (glass or rock)	12	0.04	5	
Glass				
sheet	2 500	1.00	—	—
expanded or foamed	140	0.05	10 000	
Metals				
aluminium	2 700	230	—	—
copper	8 600	384	—	—
iron	7 900	72	—	—
lead	11 340	35	—	—
steel	7 800	60	—	—
stainless steel	8 000	16	—	—
tin	7 300	65	—	—
zinc	7 000	113	—	—

Figure C.1 continued

Table C.1 — Thermal conductivities and vapour resistivities (continued)

Material	Density kg/m ³	Thermal conductivity W/m·K	Vapour resistivity	
			Typical MN·s/g·m	Range MN·s/g·m
Plaster				
gypsum	1 120	0.51	50	30 to 60
lightweight	720	0.22	30	20 to 50
Plasterboard	800	0.17	60	40 to 90
Plastic foams				
phenol	30	0.04		150 to 750
polyisocyanurate	45	0.03		150 to 750
polyurethane	30	0.03		115 to 1 000
polyvinylchloride	37	0.035		40 to 1 300
urea formaldehyde	10	0.04		5 to 20
Polystyrene				
expanded bead	20	0.035	300	100 to 600
expanded extruded	30	0.027	1 000	600 to 1 300
PVC (polyvinyl chloride) sheet or tile	1 390	0.16		800 to 1 300
Rendering	1 600	0.8	100	
Roofing				
clay tiles	2 000	0.84	Table C.2	
concrete tiles	2 100	1.50	Table C.2	
slates	2 500	2.20	Table C.2	
Roofing felt	960	0.30		
Rubber				
natural	910	0.13	4 500	
neoprene	1 240	0.23	4 500	
butyl	1 200	0.24	4 500	
foam rubber	70	0.06	4 500	
EPDM	1 150	0.25	4 500	
polyisobutylene	930	0.20	4 500	
Screed				
aerated	700	0.40		
cast	2 100	1.40		
Soil				
clay or silt	1 500	1.50	100	
sand or gravel	1 800	2.00	50	
Stonework				
basalt, gneiss, marble	2 700	3.50	∞	
granite	2 500	3.50		150 to ∞
slate	2 400	1.40		150 to 450
limestone, hard	2 200	2.30		350 to 450
limestone, soft	1 800	1.80		130 to 160
sandstone	2 600	2.30		75 to 450
pumice	400	0.12		30 to 50

Figure C.1 continued

BS 5250:2002

Table C.1 — Thermal conductivities and vapour resistivities (continued)

Material	Density kg/m ³	Thermal conductivity W/m·K	Vapour resistivity	
			Typical MN·s/g·m	Range MN·s/g·m
Tiling (ceramic)	2 300	1.30		750 to 1 500
Timber	500	0.13		90 to 700
	700	0.18		200 to 1 500
Vermiculite	260	0.07	15	
Wood based panels				
cement bonded				
particleboard	1 200	0.23		19 to 50
particleboard	300	0.10		300 to 500
particleboard	600	0.14		500 to 700
oriented strand board (OSB)	650	0.13		200 to 500
woodwool slabs	600	0.10		15 to 40
hardboard	880	0.12		250 to 1 000
sheathing plywood	500	0.13		150 to 1 000
decking plywood	700	0.17		1 000 to 6 000
fibreboard	250	0.07		150 to 400
medium density fibreboard (MDF)	600	0.14		300 to 600
cork board	110	0.04		25 to 50

NOTE 1 Although a value of 5 MN·s/g·m can be assigned to the vapour resistivity of *still* air (see Annex E), in practice the air in a cavity is never still because of ventilation or convection. Consequently, the vapour resistivity of air in cavities should be assumed to be zero, when carrying out interstitial condensation calculations.

The values in Table C.2 are vapour resistances of thin membranes and foils that are used directly in calculations.

NOTE 2 The values given in this table are the best currently available. However, data from measurements, independent certification or manufacturers' literature should be used wherever possible.

Figure C.1 continued

Table C.2 — Vapour resistances

Material	Vapour resistance	
	Typical MN·s/g	Range MN·s/g
Aluminium foil	1 000	200 to 4 000
Asphalt (laid)	10 000	
Breather membrane	0.5	0.1 to 0.6
Building paper (bitumen impregnated)	10	
Felt		
(a) roofing felt laid in bitumen	1 000	
(b) Type 1F felt	450	
Glass (sheet)	10 000	
Metals and metal cladding	10 000	
Paint		
(a) emulsion	0.5	
(b) gloss	15	8 to 40
(c) vapour resistant	25	
Polyester film (0.2 mm)	250	
Polyethylene		
(a) 500 gauge (0.12 mm)	250	200 to 350
(b) 1 000 gauge (0.25 mm)	500	400 to 600
Roof tiling or slating	2.5	0.5 to 3.0
Vinyl wallpaper	10	
NOTE 1 The values above are for the material alone and, when installed, may be considered lower.		
NOTE 2 Thermal resistances of the above may be in general considered negligible for the purposes of these calculations.		
NOTE 3 The values of asphalt, glass and metals are notional values for the purpose of calculation.		
NOTE 4 Further information on material properties, particularly vapour resistances, should be made available to the Technical Committee responsible for this standard for consideration.		

C.2 Internal humidity classifications

The tables below have been extracted from annex B of BS5250:2002 and have been reproduced with kind permission from British Standards.

The values are useful for calculations in the cold and cool temperate climates. Other internal humidity classifications can be found in EN15026²⁰, ISO 13788:2001²¹ and ASHRAE 160P²²

²⁰ EN15026:2007 *Hygrothermal Performance Of Building Components And Building Elements - Assessment Of Moisture Transfer By Numerical Simulation*

²¹ ISO 13788:2001 *Hygrothermal performance of building components and building elements - Internal surface temperature to avoid critical surface humidity and interstitial condensation - Calculation methods*

Figure C.2

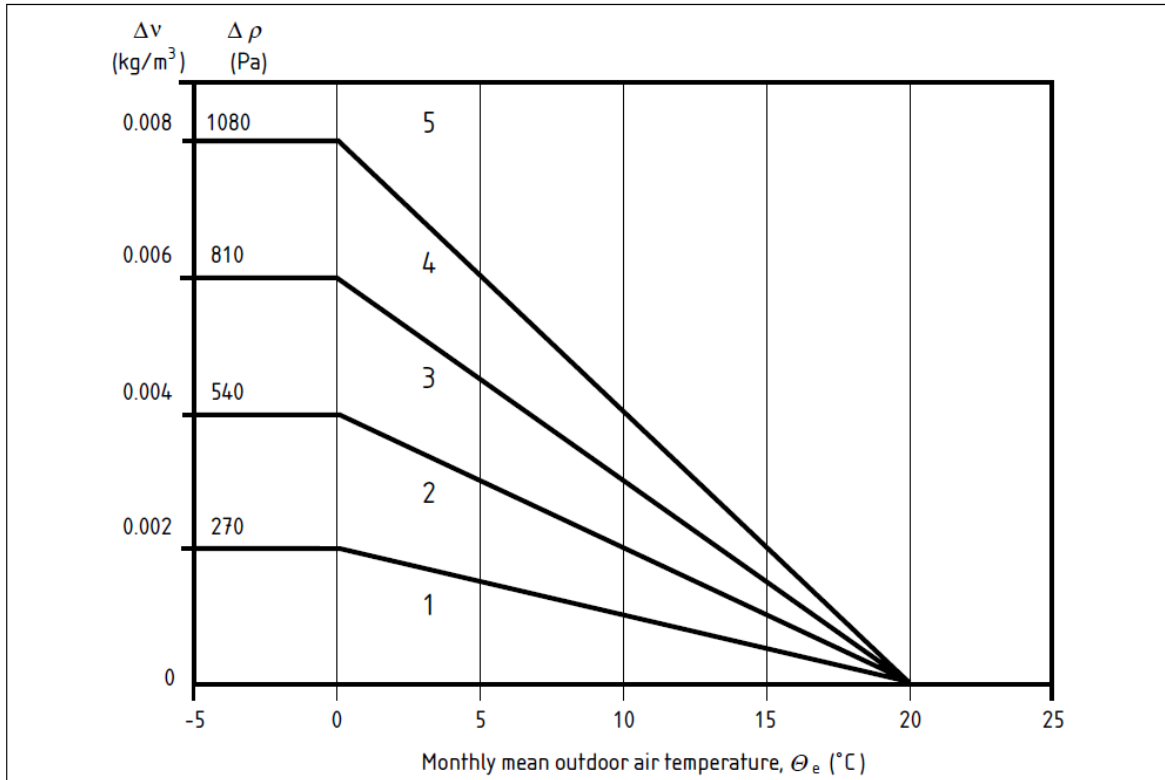

Figure B.1 — Variation of internal humidity classes with external temperature

Table B.5 — Internal humidity classes: building types and limiting relative humidities at $T_e = 0^\circ\text{C}$

Humidity class	Building type	Relative humidity at internal temperature		
		15 °C	20 °C	25 °C
1	Storage areas	<50	<35	<25
2	Offices, shops	50 – 65	35 – 50	25 – 35
3	Dwellings with low occupancy	65 – 80	50 – 60	35 – 45
4	Dwellings with high occupancy, sports halls, kitchens, canteens; buildings heated with unflued gas heaters	80 – 95	60 – 70	45 – 55
5	Special buildings, e.g. laundry, brewery, swimming pool	>95	>70	>55